

Since 1898
CONSEW®

— CONSOLIDATED SEWING MACHINE CORP.

PARTS MANUAL FOR MODELS 756R-3 & 757R-3

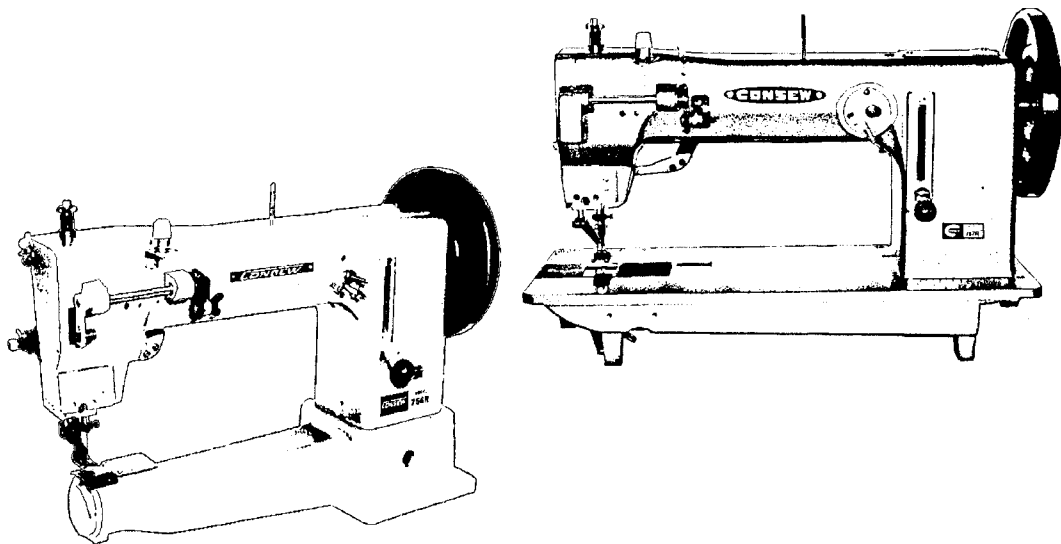

Extra Heavy Duty, Single Needle
Lower, Needle & Upper Feed (Compound Feed)
Alternating Presser Feet Lockstitch Machine
Model 756R-3: Long Cylinder Arm (15-3/4")
Model 757R-3: Long Arm Flatbed (15-3/4")

PARTS MANUAL
FOR
CONSEW MODELS 756R-3 AND 757R-3

Table of Contents

	PAGE
A. - FRAME & MISCELLANEOUS COVER COMPONENTS-----	2-3
B. - MAIN SHAFT COMPONENTS -----	4-5
C. - NEEDLE BAR - UPPER FEED MECHANISM COMPONENTS --	6-15
D. - PRESSURE BAR COMPONENTS -----	16-17
E. - FEED MECHANISM COMPONENTS -----	18-21
F. - HOOK DRIVING SHAFT COMPONENTS-----	22-25
G. - TENSION POST COMPONENTS -----	26-27
H. - THREAD WINDER & THREAD GUIDE COMPONENTS-----	28-31
I. - KNEE LIFTER COMPONENTS -----	32-33
J. - BELT COVER COMPONENTS -----	34-35
K. - THREAD STAND COMPONENTS -----	36-37
L. - TABLE COMPONENTS -----	38-39
M. - ACCESSORIES PARTS COMPONENTS -----	40-41
N. - NUMERICAL PARTS-LIST -----	42-44

A. FRAME & MISCELLANEOUS COVER COMPONENTS

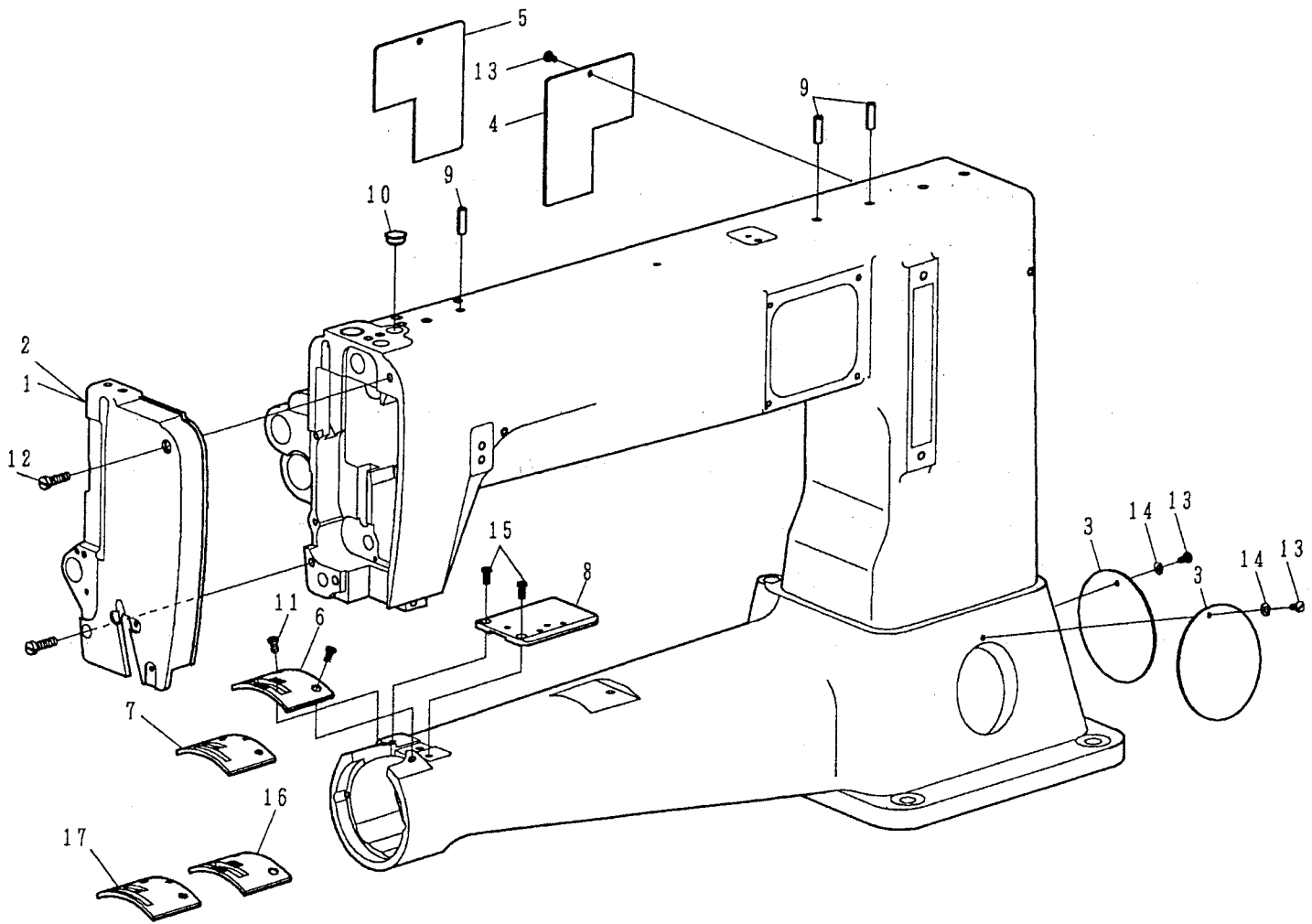

REF.No	NOTE	Part No.	Name of Part	Q'TY
1	#01	4410111005	Face Plate Asm.	1
2	#02	4710111005	Face Plate Asm.	1
3		4710111100	Side Cover, A	2
4	#01	4410111200	Side Cover, B	1
5	#02	4710111200	Side Cover, B	1
6	#01	4410111300	Throat Plate	1
7	#02	4710111300	Throat Plate	1
8		4710111600	Slide Plate	1
9		YD050018	Oil Pipe	3
10	#01	S1013-0A	Rubber Plug	1
11		ZSB12045	Screw 3/16-28 L=8	2
12		ZSB15014	Screw 15/64-28 L=18	2
13		ZSB09047	Screw 9/64-40 L=7	3
14		WC049001	Washer	2
15		ZSB11018	Screw 11/64-40 L=9	2
16	#04	4410111400	Throat Plate (Short)	(1)
17	#05	4710111400	Throat Plate (Short)	(1)

Note #01. For 757R-3
 #02. For 756R-3
 #04. Optional part for 757R-3
 #05. Optional part for 756R-3

B. MAIN SHAFT COMPONENTS

No	NOTE	Part No.	Name of Part	Q'TY
1		4710120101	- Main Shaft	1
2		4710120201	- Main Shaft Bushing, Front	1
3		4710120300	- Main Shaft Bushing, Center	1
4		4710120400	- Main Shaft Bushing, Rear	1
5		4710191301	- Thread Take Up Cam	1
6	#01	4410121000	- Needle Bar Crank Rod	1
7	#02	4710121000	Needle Bar Crank Rod	1
8		4710121100	Crank Plate	1
9		4710121300	Needle Bar Crank Shaft	1
10		4710122000	Feed Cam	1
11		4710122100	Side Plate	1
12		4710122304	Hand Wheel Asm.	1
13		4710122500	Felt	3
14		4710122601	Thrust Collar	1
15		XA200160	Oil Wick	2
16		ZSA15010	Screw 15/64-28 L=15	3
17		ZSH16001	Screw 1/4-40 L=6	2
18		YB040045	Tapered Pin 4.0X45	1
19		ZSL18001	Nut 9/32-28	1
20		ZSC18001	Screw 9/32-28 L=11	2
21		ZSH15001	Screw 15/64-28 L=7	2
22		ZSC11007	Screw 11/64-40	2
23		ZSD20003	Screw 5/16-24 L=21	2
24		ZSA16025	Screw 1/4-40 L=6	2
25		4710190100	Thread Take Up Lever	1
26		4710190200	Roller	1
27	#03	4710190220	Roller	(1)
28	#03	4710190230	Roller	(1)
29		4710190300	Roller Stud	1
30		ZSG20012	Hinge Screw	1
31		RE000040	E-Shaped Snap Ring (4mm)	1
32		ZSL18001	Nut 9/32-28	1

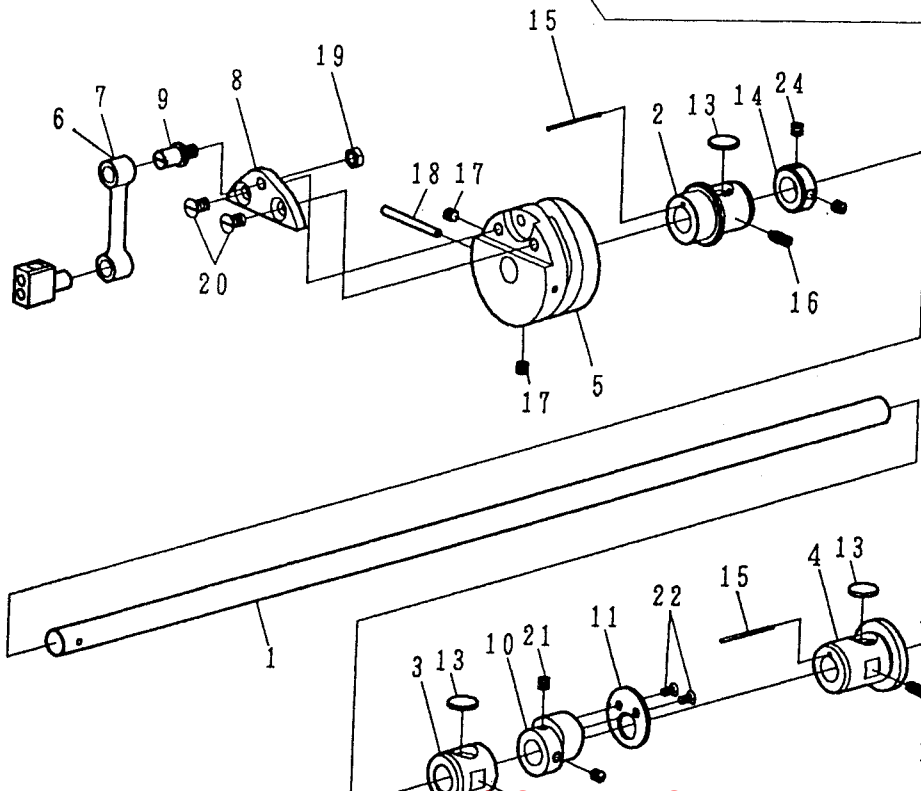
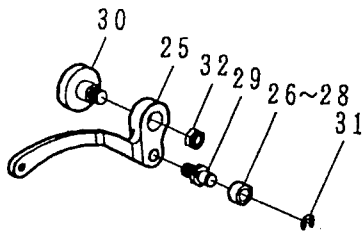

Notes #01. For 757R-3
 #02. For 756R-3
 #03. Elective part

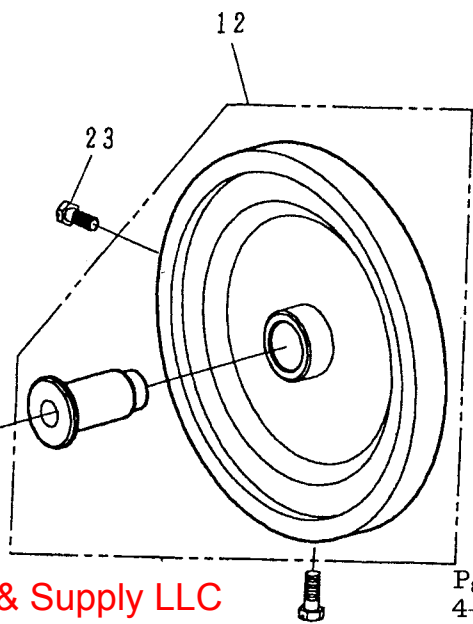

C. NEEDLE BAR · UPPER FEED MECHANISM COMPONENTS (For 757R-3)

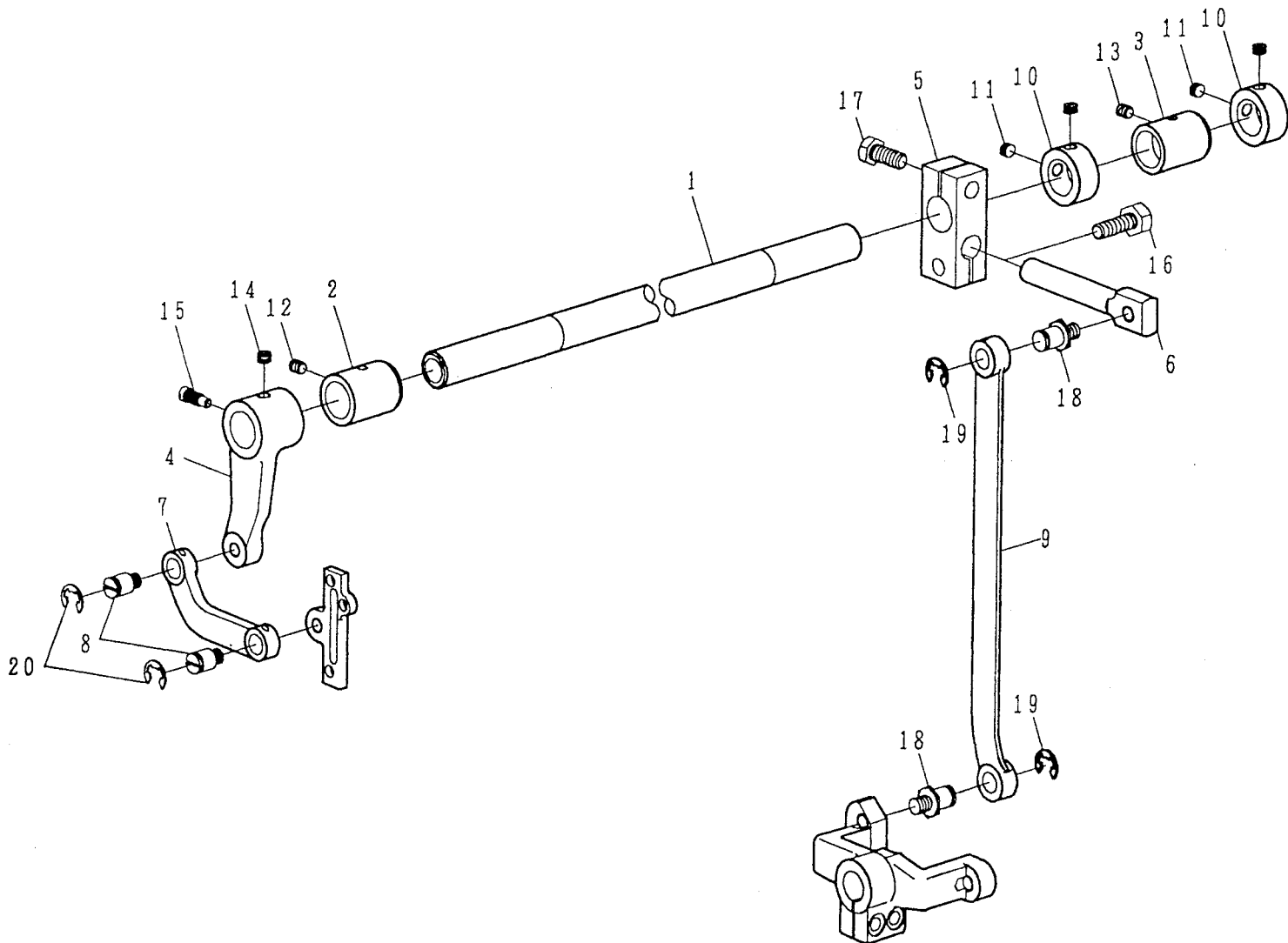

REF.No	NOTE	Part No.	Name of Part	Q'TY
1	#01	4410142100	Driving Shaft-----	1
2	#01	4410145600	Driving Shaft Front Metal ----	1
3	#01	4710142201	Driving Shaft Rear Metal ----	1
4	#01	4410142300	Driving Shaft Rod , Front----	1
5	#01	4410142400	Driving Shaft Rod , Rear ----	1
6	#01	4410141900	Driving Shaft Rear Arm Pin ----	1
7	#01	4410143100	Frame Driving Link -----	1
8	#01	ZSK18019	Hinge Screw-----	2
9	#01	4410142000	Frame Driving Rod -----	1
10	#01	LG4043-0A	Thrust Collar D=18 W=12 ----	2
11	#01	ZSA16010	Screw 1/4-40 L=4.5 -----	4
12	#01	ZSA15028	Screw 15/64-28 L=7 -----	1
13	#01	ZSA15028	Screw 15/64-28 L=7 -----	1
14	#01	ZSH16005	Screw 1/4-40 L=4.5 -----	1
15	#01	ZSB15015	Screw 15/64-28 L=14.5 ----	1
16	#01	ZSD20011	Screw 5/16-18 L=23 -----	1
17	#01	ZSD20009	Screw 5/16-18 L=25 -----	1
18	#01	ZSK20009	Hinge Screw-----	2
19	#01	RE000080	E-Shaped Snap Ring (8mm)-	2
20	#01	RE000080	E-Shaped Snap Ring (8mm)-	2

Notes #01. For 757R-3

C. NEEDLE BAR · UPPER FEED MECHANISM COMPONENTS (For 757R-3)

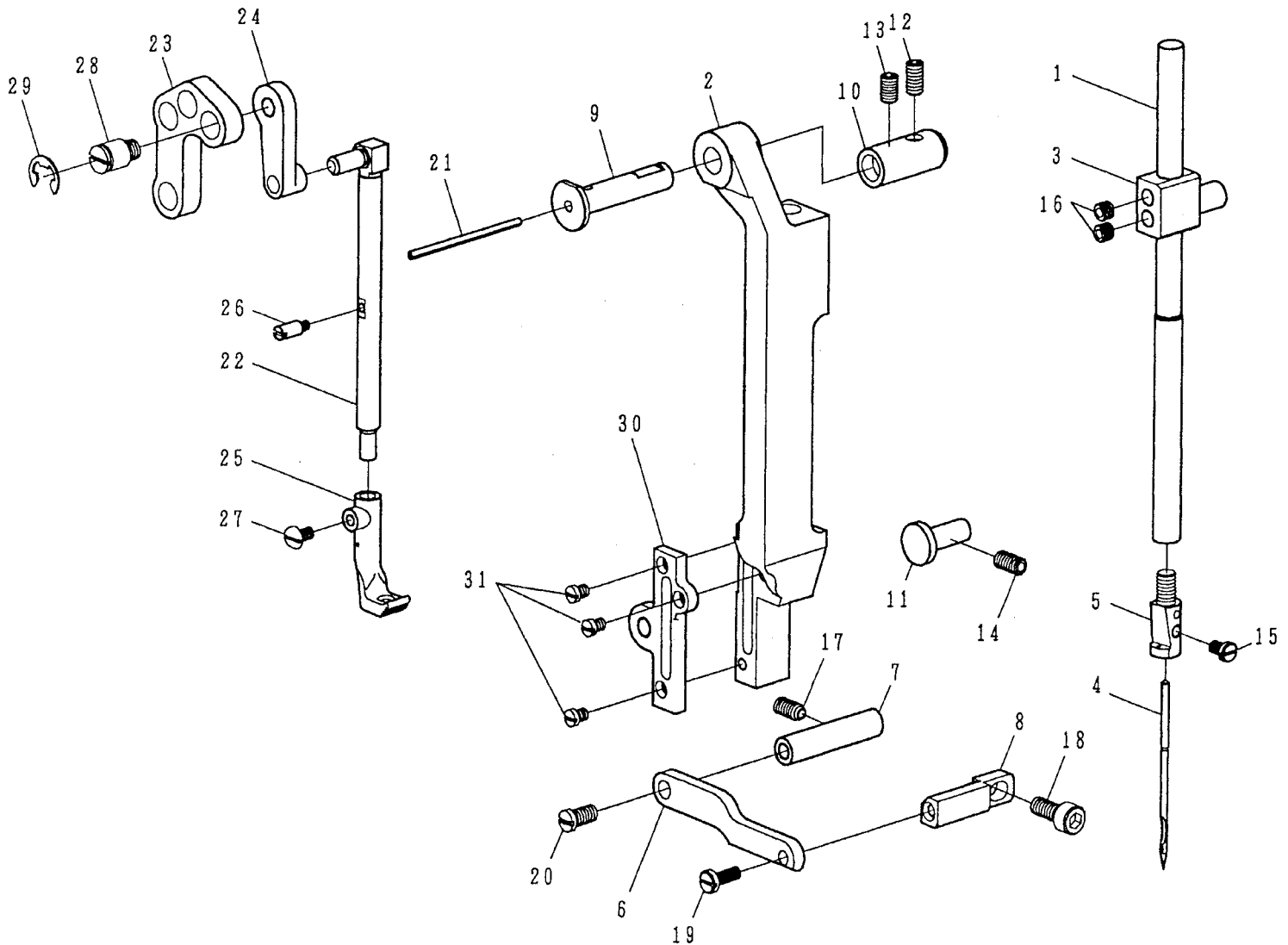

REF. No	NOTE	Part No.	Name of Part	Q'TY	REF. No	NOTE	Part No.	Name of Part	Q'TY
1	#01	4410140100	Needle Bar	1	18	#01	ZMJ06002	Screw M6 L=21	1
2	#01	4410270100	Frame Driving Base	1	19	#01	ZSB11076	Screw 11/64-40 L=12	1
3	#01	4410140900	Needle Bar Connection	1	20	#01	ZSB15004	Screw 15/64-28 L=10.5	1
4	#01	IN794#230	Needle (794 Nm=230-4)	1	21	#01	XA200100	Oil Wick	1
5	#01	4410140200	Needle Stopper	1	22	#01	4410150100	Upper Feed Bar	1
6	#01	4410143700	Pressure Plate	1	23	#01	4410143600	L Link	1
7	#01	4410272300	Setting Shaft	1	24	#01	4410143300	Upper Feed Frame Driving Link	1
8	#01	4410272200	Setting Plate	1	25	#01	4410151000	Pressure Foot	1
9	#01	4410270200	Frame Driving Base Shaft	1	26	#01	4410142900	Upper Feed Bar Pin	1
10	#01	4410273000	Frame Driving Base Shaft Metal	1	27	#01	ZSB11041	Screw 11/64-40 L=7	1
11	#01	4410270400	Frame Driving Base Guide	1	28	#01	ZSK18019	Hinge Screw	1
12	#01	ZMH06005	Screw M6 L=12	1	29	#01	RE000080	E-Shaped Snap Ring (8mm)	1
13	#01	ZMH06010	Screw M6 L=10	1	30	#01	4410151100	Guide Plate	1
14	#01	ZMH06005	Screw M6 L=12	1	31	#01	ZSB11042	Screw 11/64-40 L=4.5	3
15	#01	ZSB11022	Screw 11/64-40 L=7	1					
16	#01	ZSH16005	Screw 1/4-40 L=4.5	2					
17	#01	ZMH06005	Screw M6 L=12	1					

Notes #01. For 757R-3

C. NEEDLE BAR · UPPER FEED MECHANISM COMPONENTS (For 756R-3)

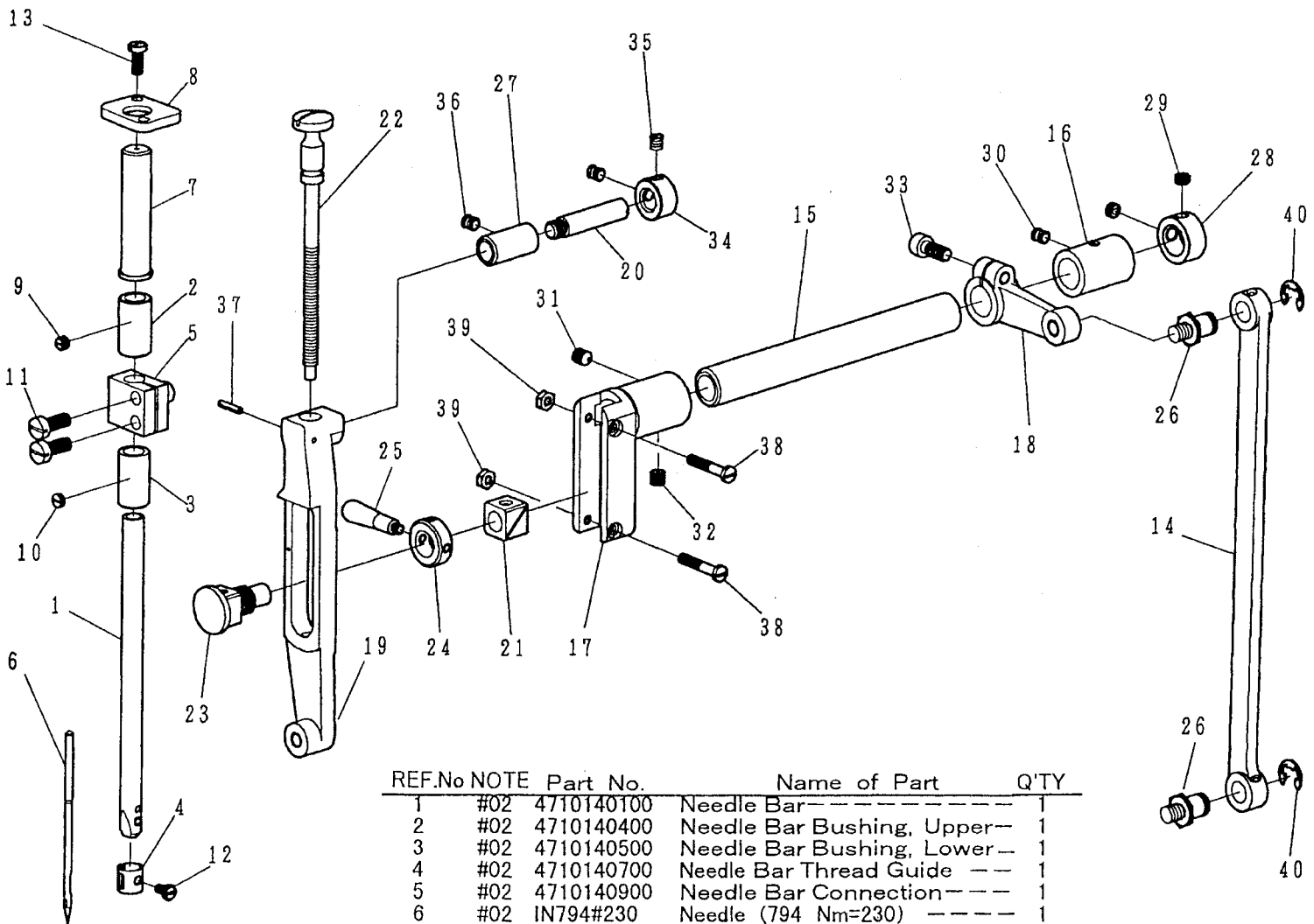

REF.No	NOTE	Part No.	Name of Part	Q'TY
1	#02	4710140100	Needle Bar	1
2	#02	4710140400	Needle Bar Bushing, Upper	1
3	#02	4710140500	Needle Bar Bushing, Lower	1
4	#02	4710140700	Needle Bar Thread Guide	1
5	#02	4710140900	Needle Bar Connection	1
6	#02	IN794#230	Needle (794 Nm=230)	1
7	#02	4710141200	Needle Bar Cover	1
8	#02	4710141300	Cover Plate	1
9	#02	ZSA15013	Screw 15/64-28 L=3.4	1
10	#02	ZSA16039	Screw 1/4-40 L=2.5	1
11	#02	ZSB15032	Screw 15/64-28 L=14	2
12	#02	ZSB11030	Screw 11/64-40 L=6.5	1
13	#02	ZSB11076	Screw 11/64-40 L=12	2
14	#02	4710142000	Lengthwise Feed Rod	1
15	#02	4710142101	Driving Shaft	1
16	#02	4710142201	Bushing, Rear	1
17	#02	4710142301	Driving Shaft Rod, Front	1
18	#02	4710142401	Driving Shaft Rod, Rear	1
19	#02	4710142500	Upper Feed Control Bracket	1
20	#02	4710142600	Shaft	1
21	#02	4710142700	Brock	1
22	#02	4710142800	Screw	1
23	#02	4710142900	Shaft	1
24	#02	4710143000	Nut	1
25	#02	4710143900	Control Lever	1
26	#02	ZSK20009	Hinge Screw	2
27	#02	4710140500	Bushing	1
28	#02	LG4043-0A	Thrust Collar D=18 W=10	1
29	#02	ZSA16010	Screw 1/4-40 L=4.5	2
30	#02	ZSA15028	Screw 15/64-28 L=7	1
31	#02	ZSH16002	Screw 1/4-40 L=8.5	1
32	#02	ZSH16001	Screw 1/4-40 L=6	1
33	#02	ZMJ06002	Screw M6 L=15	1
34	#02	LG1274-0A	Thrust Collar D=9.53 W=10	1
35	#02	ZSA15028	Screw 15/64-28 L=7	2
36	#02	ZSA15028	Screw 15/64-28 L=7	1
37	#02	YD025014	Spring Pin 2.8X14	1
38	#02	ZSB11057	Screw 11/64-40 L=24	2
39	#02	ZSL11094	Nut 1/4-40	1
40	#02	RE000080	E-Shaped Snap Ring (8mm)	2

Notes #02. For 756R-3

C. NEEDLE BAR · UPPER FEED MECHANISM COMPONENTS (For 756R-3)

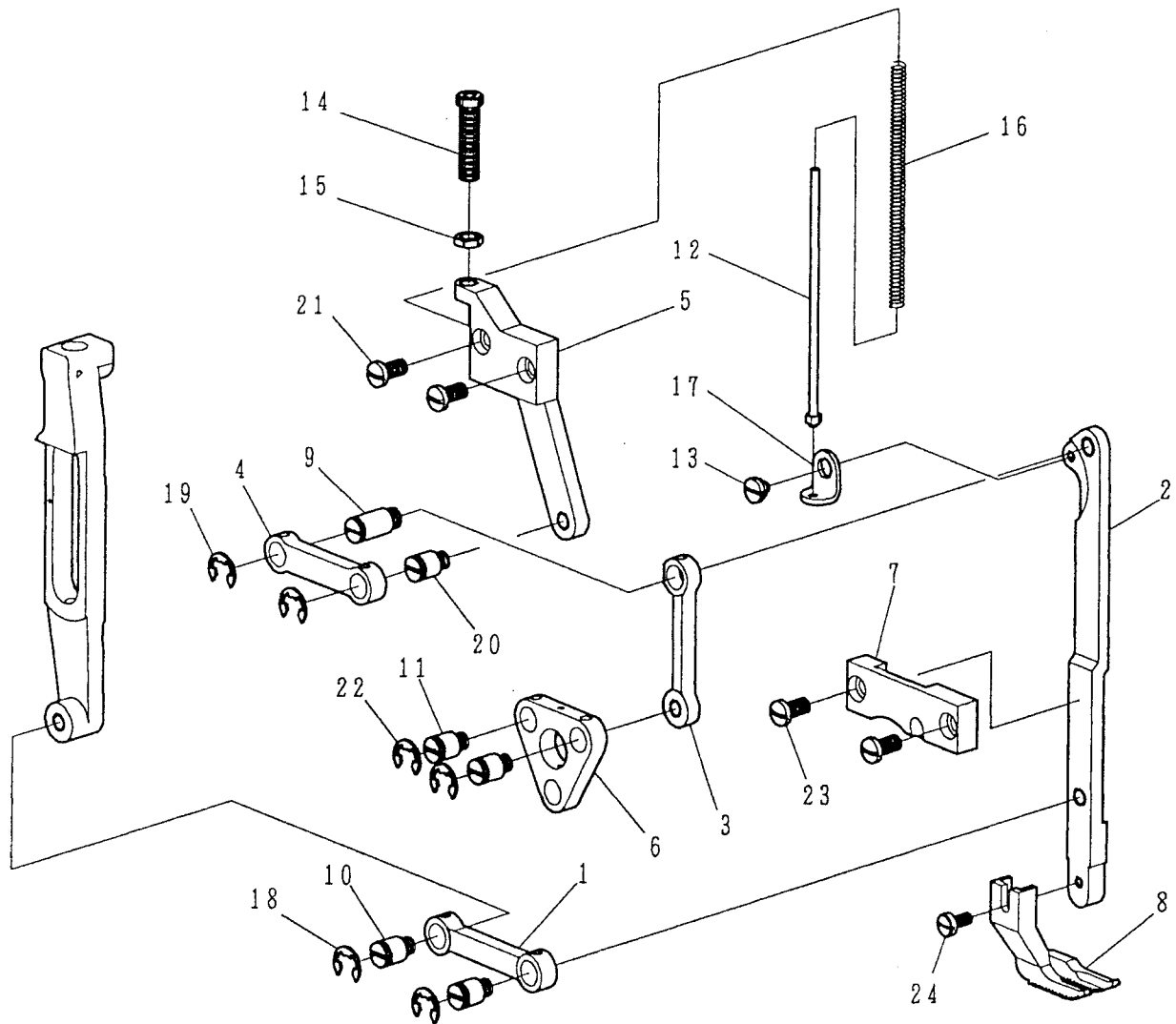

REF.No	NOTE	Part No.	Name of Part	Q'TY
1	#02	4710143100	Rod	1
2	#02	4710143200	Upper Feed Rod	1
3	#02	4710143300	Upper Feed Link A	1
4	#02	4710143400	Upper Feed Link B	1
5	#02	4710143500	Upper Feed Link Bracket	1
6	#02	4710143600	Bracket	1
7	#02	4710143700	Supporting Plate	1
8	#02	4710143800	Walking Foot (Standard)	1
9	#02	ZSK20006	Hinge Screw	1
10	#02	ZSK18019	Hinge Screw	2
11	#02	ZSK18019	Hinge Screw	2
12	#02	4710144100	Spring Guide Bar	1
13	#02	ZSG11058	Hinge Screw	1
14	#02	ZSF18001	Adjusting Thumb Screw	1
15	#02	ZSL18003	Nut 9/32-28	1
16	#02	4710144200	Spring	1
17	#02	E1288-0A	Retaining Plate	1
18	#02	RE000080	E-Shaped Snap Ring (8mm)	2
19	#02	RE000080	E-Shaped Snap Ring (8mm)	2
20	#02	ZSK18019	Hinge Screw	1
21	#02	ZSB15005	Screw 15/64-28 L=12	2
22	#02	RE000080	E-Shaped Snap Ring (8mm)	2
23	#02	ZSB15005	Screw 15/64-28 L=12	2
24	#02	ZSB11026	Screw 11/64-40 L=9.5	1

Notes #02. For 756R-3

C. NEEDLE BAR · UPPER FEED MECHANISM COMPONENTS

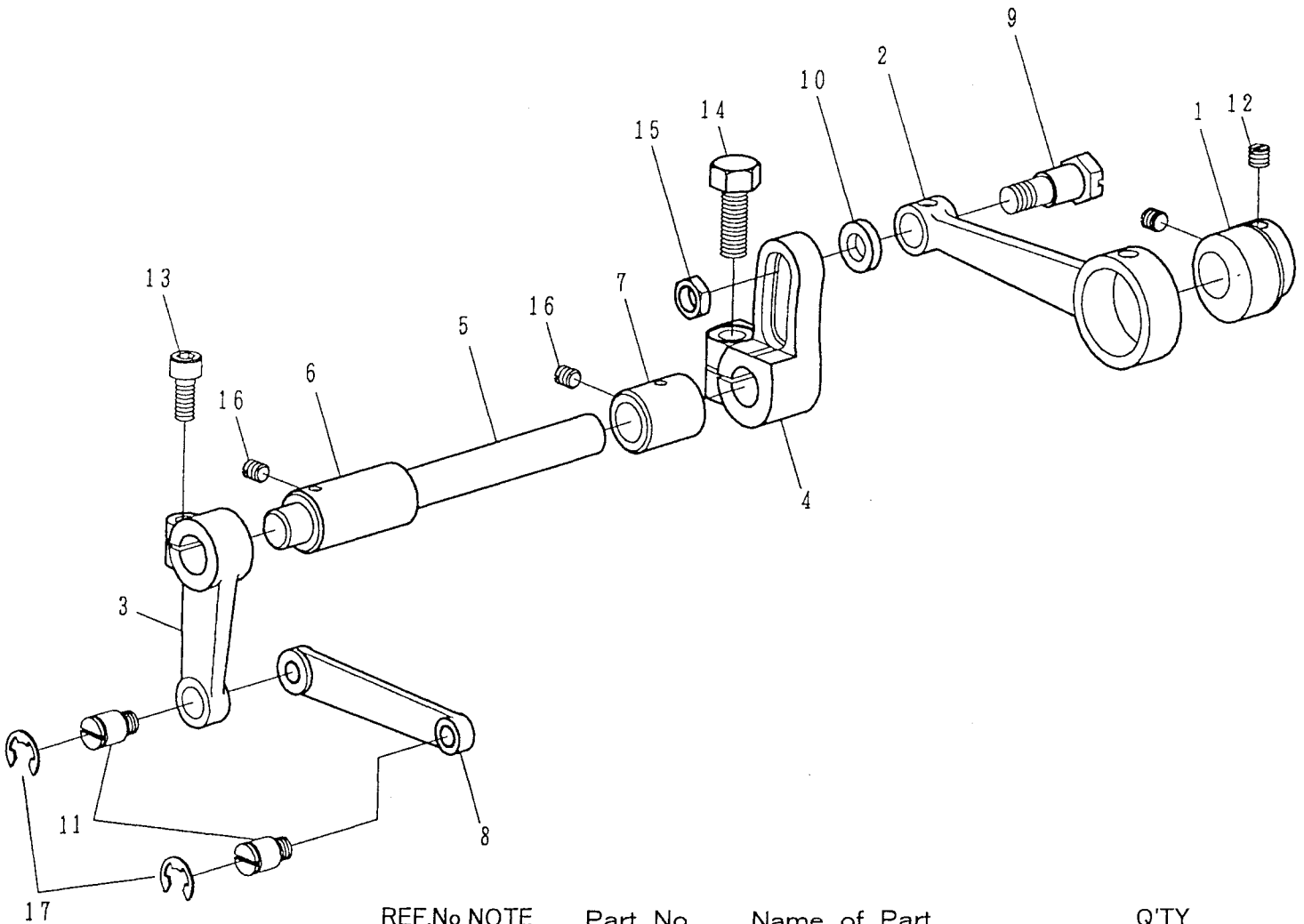

REF.No	NOTE	Part No.	Name of Part	Q'TY
1		4710144401	Driving Cam	1
2		4710144500	Connecting Rod	1
3		4710144600	Driving Shaft Arm, Front	1
4		4710144700	Driving Shaft Arm, Rear	1
5		4710144800	Feed Rocker Shaft	1
6		4710144900	Bushing, Front	1
7		4710145000	Bushing, Rear	1
8		4710145100	Rod	1
9		ZSG22002	Hinge Screw	1
10		WH208005	Washer	1
11		ZSK18019	Hinge Screw	2
12		ZSA16025	Screw 1/4-40 L=6	2
13		ZMJ06002	Screw M6 L=21	1
14		ZSD20011	Screw 5/16-18	1
15		ZSL22001	Nut 11/32-28	1
16		ZSA15028	Screw 15/64-28 L=7	2
17		RE000080	E-Shaped Snap Ring (8mm)	2

D. PRESSURE BAR COMPONENTS

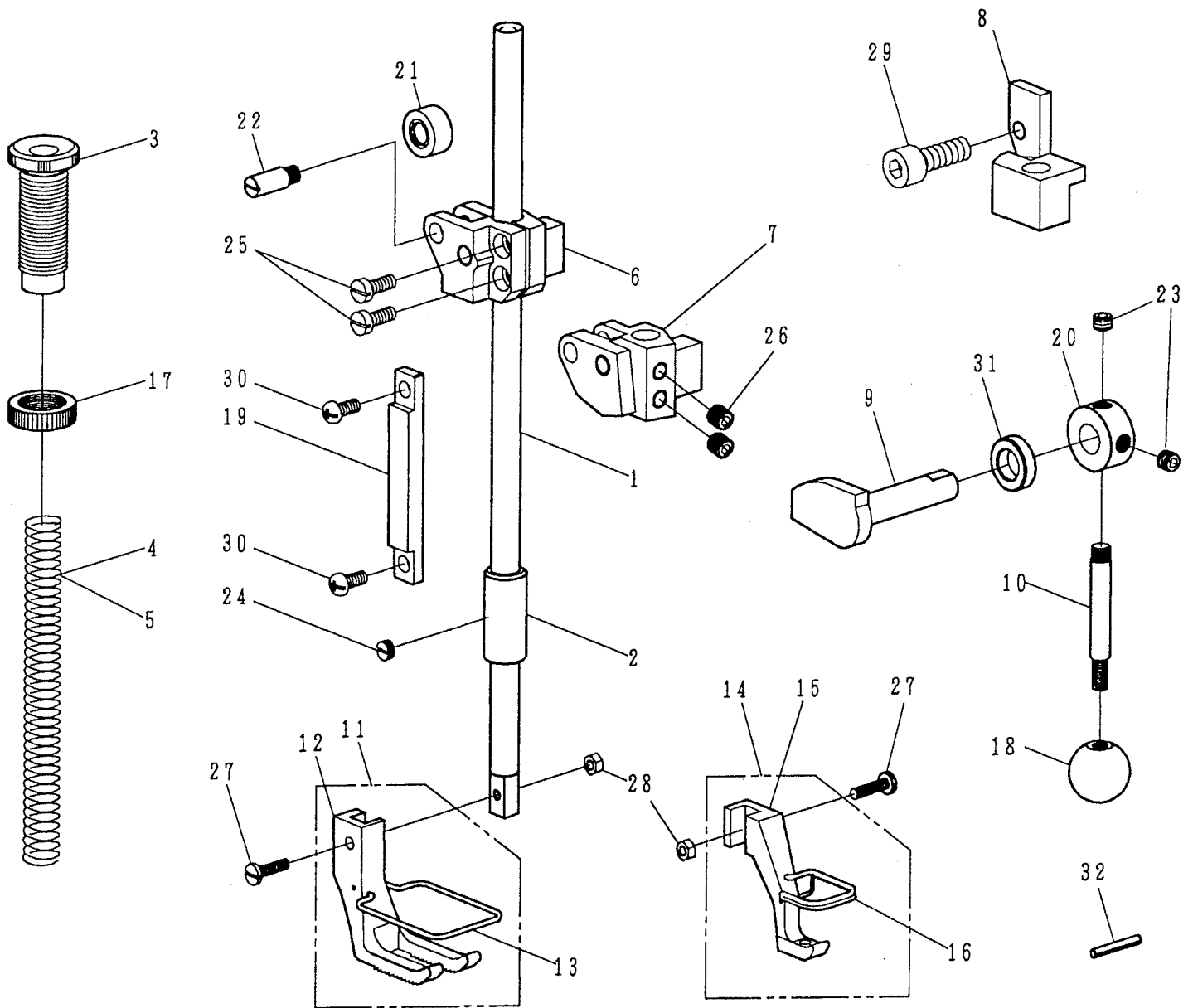

REF. No.	NOTE	Part No.	Name of Part	Q'TY
1		4710150100	Presser Bar	1
2		4710150200	Presser Bar Bushing	1
3		4710150300	Screw	1
4	#01	4410150400	Spring	1
5	#02	4710150400	Spring	1
6	#01	4410150500	Presser Bar Guide Bracket	1
7	#02	4710150500	Presser Bar Guide Bracket	1
8		4710150600	Hand Lifter Link	1
9		4710150700	Hand Lifter Cam	1
10		4710150800	Hand Lifter Lever	1
11	#01	4410143805	Pressure Foot (Standard) Asm.	1
12	#01	4410143800	Pressure Foot (Standard)	(1)
13	#01	4410152500	Guard	(1)
14	#02	4710151005	Pressure Foot (Standard) Asm.	1
15	#02	4710151000	Pressure Foot (Standard)	(1)
16	#02	4710152500	Guard	(1)
17		4710151500	Nut	1
18		4710151600	Grip	1

REF. No.	NOTE	Part No.	Name of Part	Q'TY
19		4710151700	Guide Plate	1
20		4710151800	Thrust Collar	1
21		4710151900	Roller Follower	1
22		4710152000	Guide Pin	1
23		ZSH16005	Screw 1/4-40 L=4.5	2
24		ZSA16039	Screw 1/4-40 L=2.5	1
25	#01	ZSB12002	Screw 3/16-28 L=12	2
26	#02	ZSH16001	Screw 1/4-40 L=6	2
27		ZSB09061	Screw 9/64-40 L=13.5	1
28		ZSL09001	Nut 9/64-40	1
29		ZSJ16001	Screw 1/4-40 L=6.5	1
30		ZSB12016	Screw 3/16-32 L=10	2
31		WA100009	Collar	1
32		YD030020	Spring Pin 3.0X20	1

Notes #01. For 757R-3
#02. For 756R-3

E. FEED MECHANISM COMPONENTS (1/2)

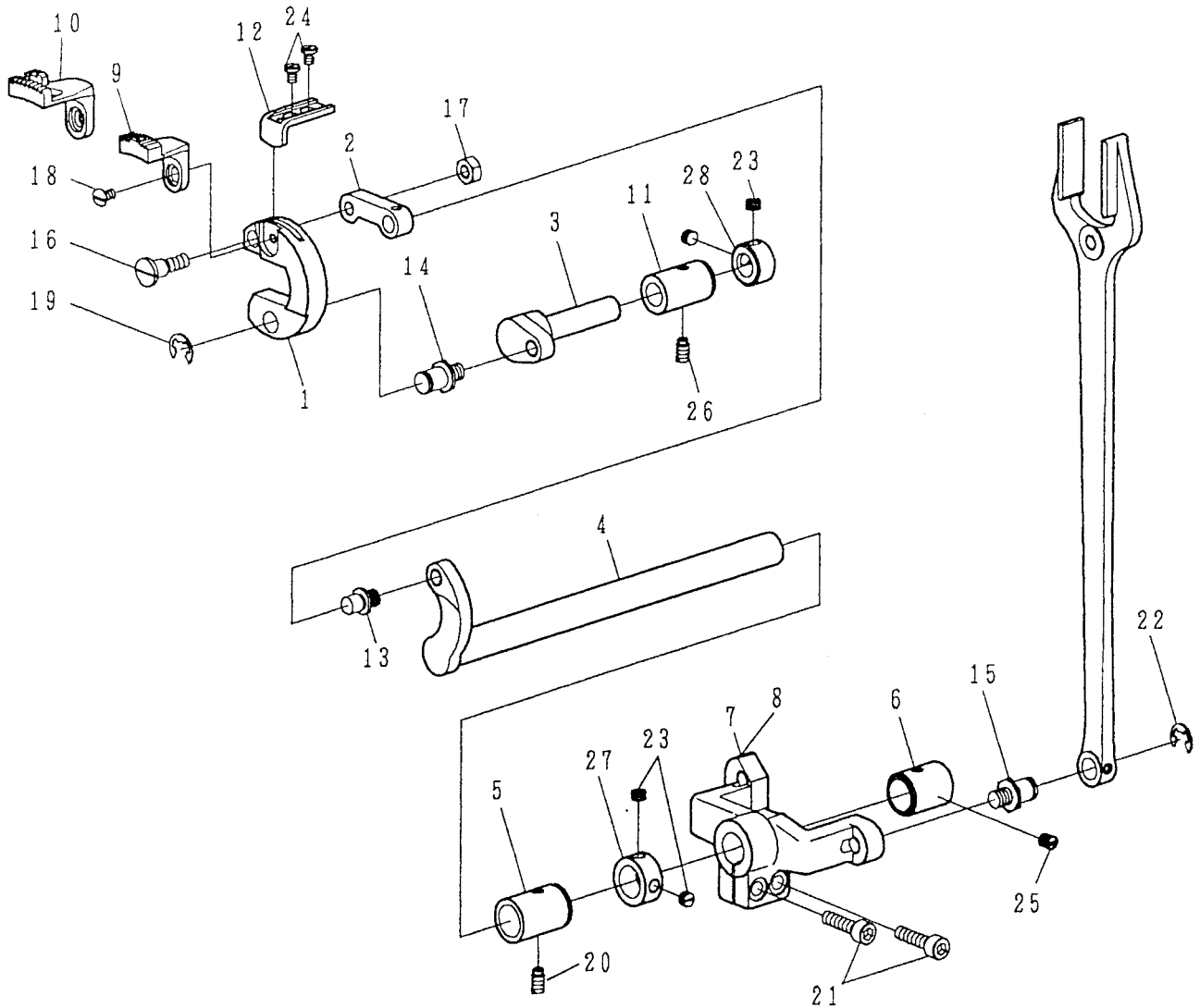

REF. No	NOTE	Part No.	Name of Part	Q'TY
1		4710160100	Feed Bar	1
2		4710160200	Feed Bar Link	1
3		4710160300	Driving Shaft	1
4		4710160404	Feed Rocker Shaft	1
5		4710160600	Bushing, Front	1
6		4710160700	Bushing, Rear	1
7	#01	4410160800	Feed Rocker Shaft Crank	1
8	#02	4710160800	Feed Rocker Shaft Crank	1
9	#01	4410161400	Feed Dog	1
10	#02	4710161400	Feed Dog	1
11		4710161700	Driving Shaft Metal	1
12		4710162100	Feed Bar Presser	1
13		ZSK20007	Hinge Screw	1
14		ZSK20009	Hinge Screw	1
15		ZSK20009	Hinge Screw	1
16		ZSG16024	Hinge Screw D=7.94 L=8	1
17		ZSL16004	Nut 1/4-24	1

REF. No	Part No.	Name of Part	Q'TY
18	ZSB11041	Screw 11/64-40 L=7	1
19	RE000080	E-Shaped Snap Ring (8mm)	1
20	ZSA15037	Screw 15/64-28 L=10.5	1
21	ZMJ06004	Screw M6	2
22	RE000080	E-Shaped Snap Ring (8mm)	1
23	ZSA16029	Screw 1/4-40 L=3.5	4
24	ZSB11035	Screw 11/64-40 L=6	2
25	ZSA15028	Screw 15/64-28 L=7	1
26	ZSA15037	Screw 15/64-28 L=10.5	1
27	LG4044-0A	Thrust Collar D=14.72 W=10	1
28	LG4014-0A	Thrust Collar D=11.11 W=10	1

Notes #01. For 757R-3
#02. For 756R-3

E. FEED MECHANISM COMPONENTS (2/2)

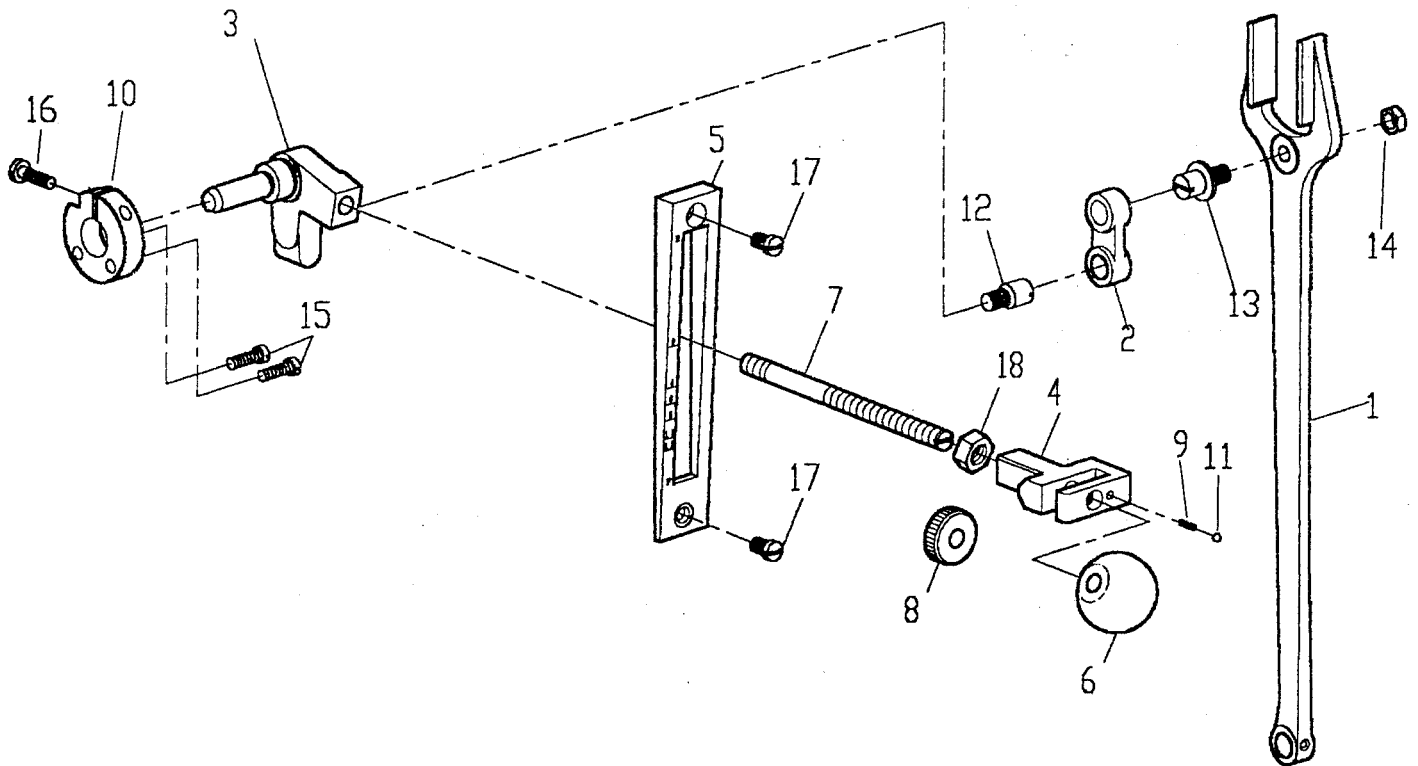

REF.No	Part No.	Name of Part	Q'TY
1	4710160900	Rod -----	1
2	4710161000	Feed Connecting Link --	1
3	4710161100	Feed Regulator -----	1
4	4710161200	Lever -----	1
5	4710161300	Side Cover-----	1
6	4710161600	Lever Grip-----	1
7	4710161800	Lever Shaft -----	1
8	4710161900	Nut -----	1
9	4710162000	Spring-----	1
10	4710162200	Support Plate -----	1
11	4710162300	Ball -----	1
12	ZSK18018	Hinge Screw, A -----	1
13	ZSK18020	Hinge Screw, B -----	1
14	ZSL18001	Nut 9/32-28 -----	1
15	ZSB12015	Screw 3/16-28 L=12 ---	2
16	ZSB12036	Screw 3/16-32 L=18 ---	1
17	ZSB15019	Screw 15/64-28 L=9 ---	2
18	ZML08001	Nut -----	1

F. HOOK DRIVING SHAFT COMPONENTS

(1/2)

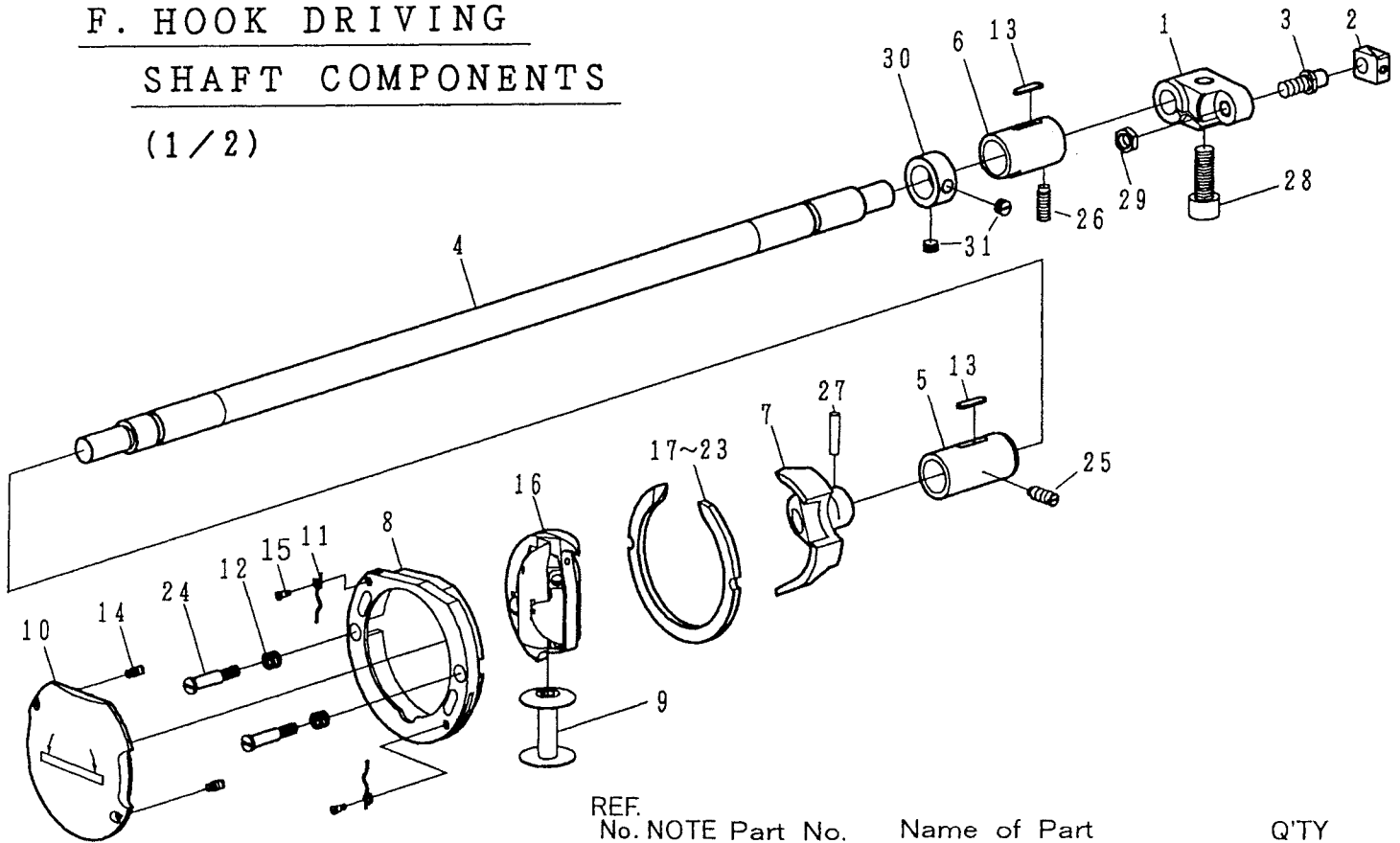

REF. No.	NOTE	Part No.	Name of Part	Q'TY
1		4710182500	Hook Driving Shaft Crank	1
2		4710182600	Crank Slide Block	1
3		4710182700	Slide Block Stud	1
4		4710180100	Hook Driving Shaft	1
5		4710180300	Bushing, Front	1
6		4710180500	Bushing, Rear	1
7		4410181600	Shuttle Driver	1
8		4710181400	Shuttle Race Body	1
9		4710183200	Bobbin	1
10		4710183600	Hook Cover	1
11		4710183700	Hook Cover Spring	2
12		4710183800	Hook Counter Sprig	2
13		4710183900	Oil Felt	2
14		4710184000	Screw	2
15		ZSG06004	Hinge Screw D=2.6 L=2.7	2
16		4710181300	Hook Cover	1
17	#03	4710184210	Distance Piece	(1)
18	#03	4710184220	Distance Piece	(1)
19	#03	4710184230	Distance Piece	(1)
20		4710184200	Distance Piece (Standard)	1
21	#03	4710184240	Distance Piece	(1)
22	#03	4710184250	Distance Piece	(1)
23	#03	4710184260	Distance Piece	(1)
24		ZSG12047	Screw	2
25		ZSA15010	Screw 15/64-28 L=15	1
26		ZSA15010	Screw 15/64-28 L=15	1
27		YB040016	Tapered Pin 4.0X16	1
28		ZMJ08003	Screw M8 L=30	1
29		ZSL18003	Nut 9/32-28	1
30		LG4044-0A	Thrust Collar D=14.72 W=10-	1
31		ZSA16029	Screw 1/4-40 L=3.5	2

Notes #03. Elective part

F. HOOK DRIVING SHAFT COMPONENTS (2/2)

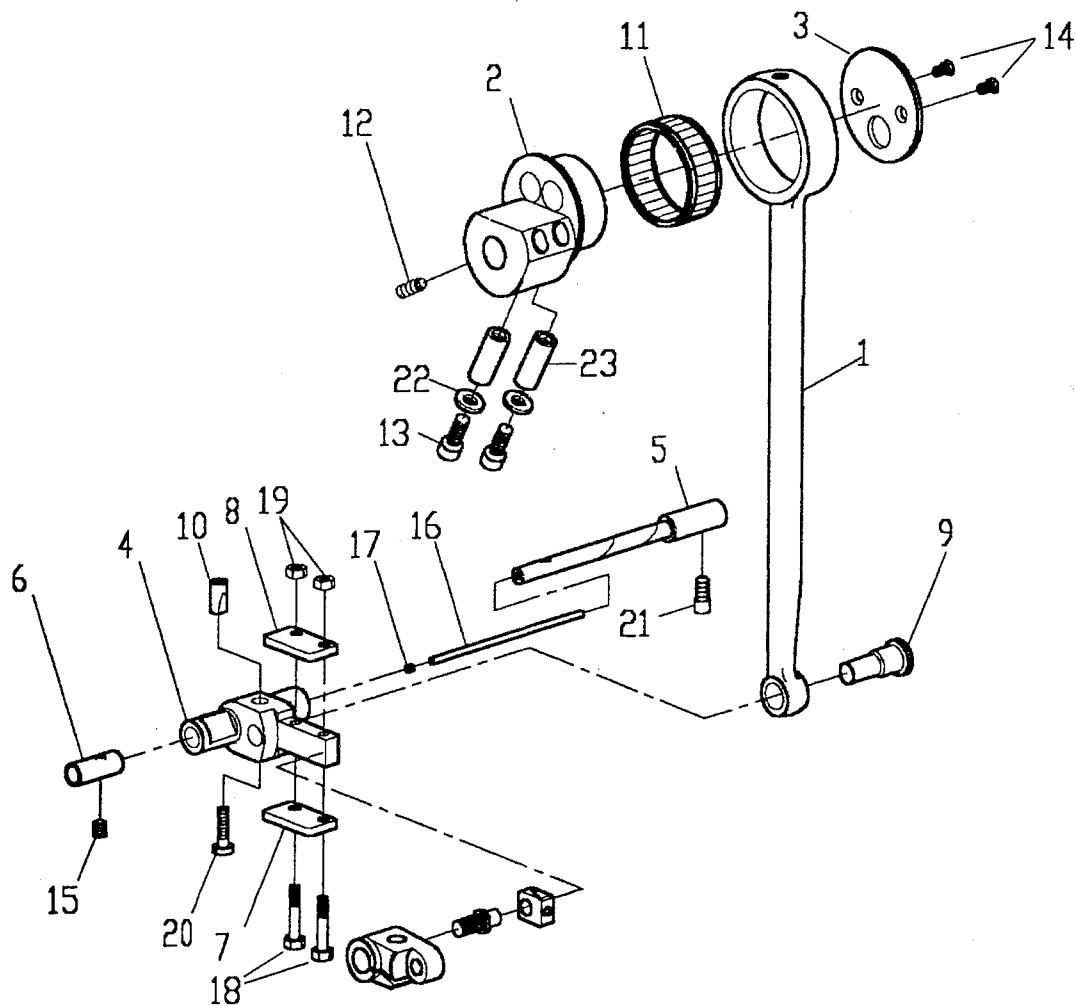

REF.No.	Part No.	Name of Part	Q'TY
1	4710181800	Connecting Rod	1
2	4710181900	Con-Rod Eccentric Cam	1
3	4710182000	Cam Side Plate	1
4	4710182200	Oscilating Rock Shaft	1
5	4710182300	Hjnge Pin	1
6	4710182400	Rock Shaft Bushing	1
7	4710182800	Slide Plate A	1
8	4710182900	Slide Plate B	1
9	4710183000	Con-Rod Pin	1
10	4710183100	Con-Rod Pin Wedge	1
11	4710182100	Cage&Roller	1
12	ZSH15006	Screw 15/64-28 L=15	1
13	ZMJ06006	Screw M8 L=30	2
14	ZSC11002	Screw 11/64-40 L=7	2
15	ZSA15028	Screw 15/64-28 L=7	1
16	XA300085	Oil Wick	1
17	LG1275-0A	Plug 2.9X3.2X3	1
18	ZSD11010	Screw	2
19	ZSL11002	Nut 11/64-40	2
20	ZSB12036	Screw 3/16-32 L=18	1
21	ZSJ15001	Screw 15/64-28 L=10.7	1
22	4710183400	PIN	2
23	WA06008	Washer	2

G. TENSION POST COMPONENTS

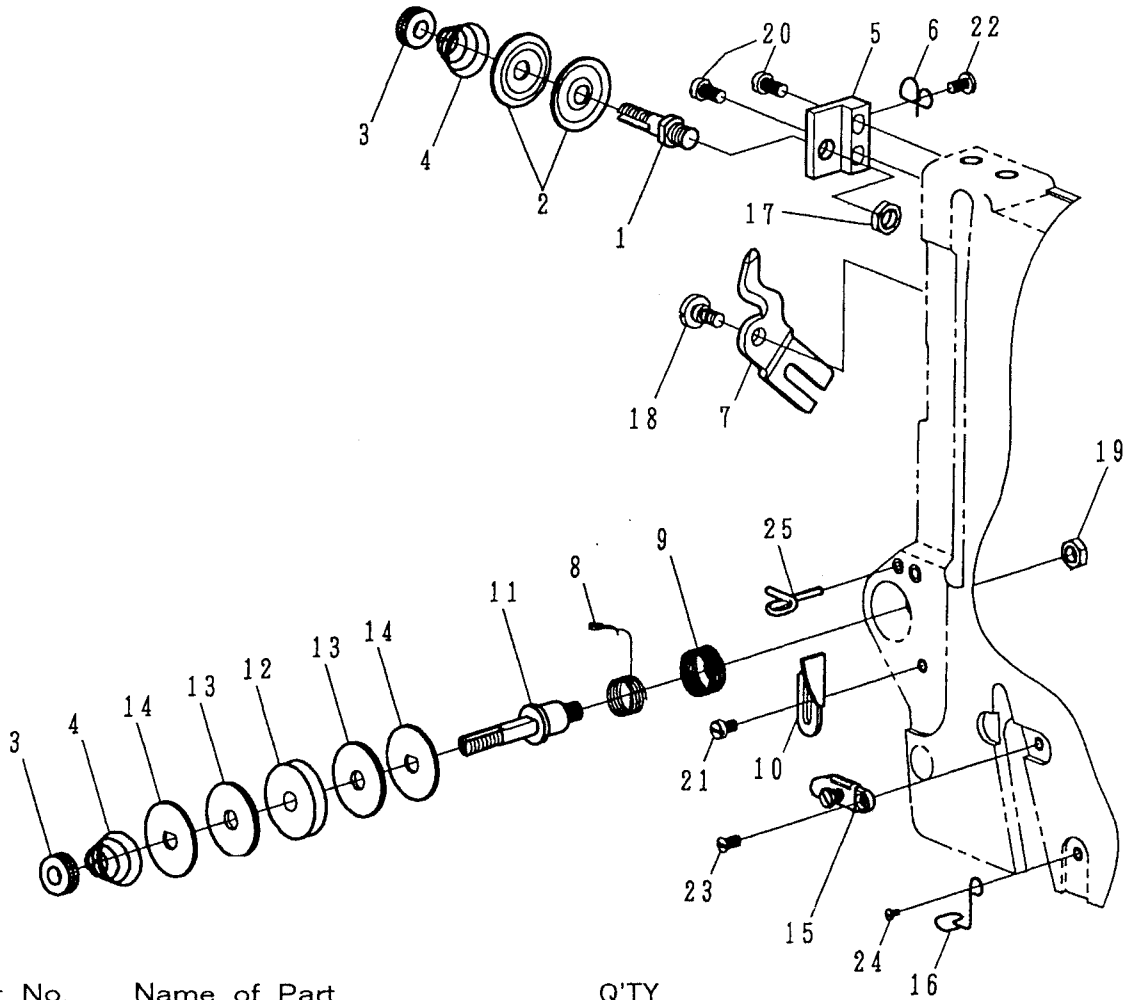

REF.No	Part No.	Name of Part	Q'TY
1	4710310100	Thread Tension Post	1
2	A1025-0A	Tension Disk	2
3	ZSN16004	Thread Tension Stud Nut	2
4	4710310400	Thread Tension Spring	2
5	4710310500	Thread Tension Post Bracket	1
6	4710310600	Thread Tension Guide	1
7	4710310700	Thread Releasing Plate	1
8	4710310800	Spring A	1
9	4710310900	Spring B	1
10	4710311000	Spring Support Plate	1
11	4710311100	Thread Tension Wheel Post	1
12	4710311200	Thread Tension Wheel	1
13	XB123001	Wheel Felt	2
14	4710311400	Felt Support Plate	2
15	4710311605	Arm Thread Guide Bottom Asm.	1
16	4710312000	Frame Thread Guide	1
17	ZSL18003	Nut 9/32-28	1
18	ZSG12046	Hinge Screw D=6.0 L=3.2	1
19	ZSL15002	Nut 15/64-28	1
20	ZSB11011	Screw 11/64-40 L=9	2
21	ZSB09014	Screw 9/64-40 L=6.0	1
22	ZSB09047	Screw 9/64-40 L=7	1
23	ZSC09005	Screw 9/64-40 L=5	1
24	ZSB09047	Screw 9/64-40 L=7	1
25	4710313100	Thread Guide	1

H. THREAD WINDER & THREAD GUIDE COMPONENTS (1/2)

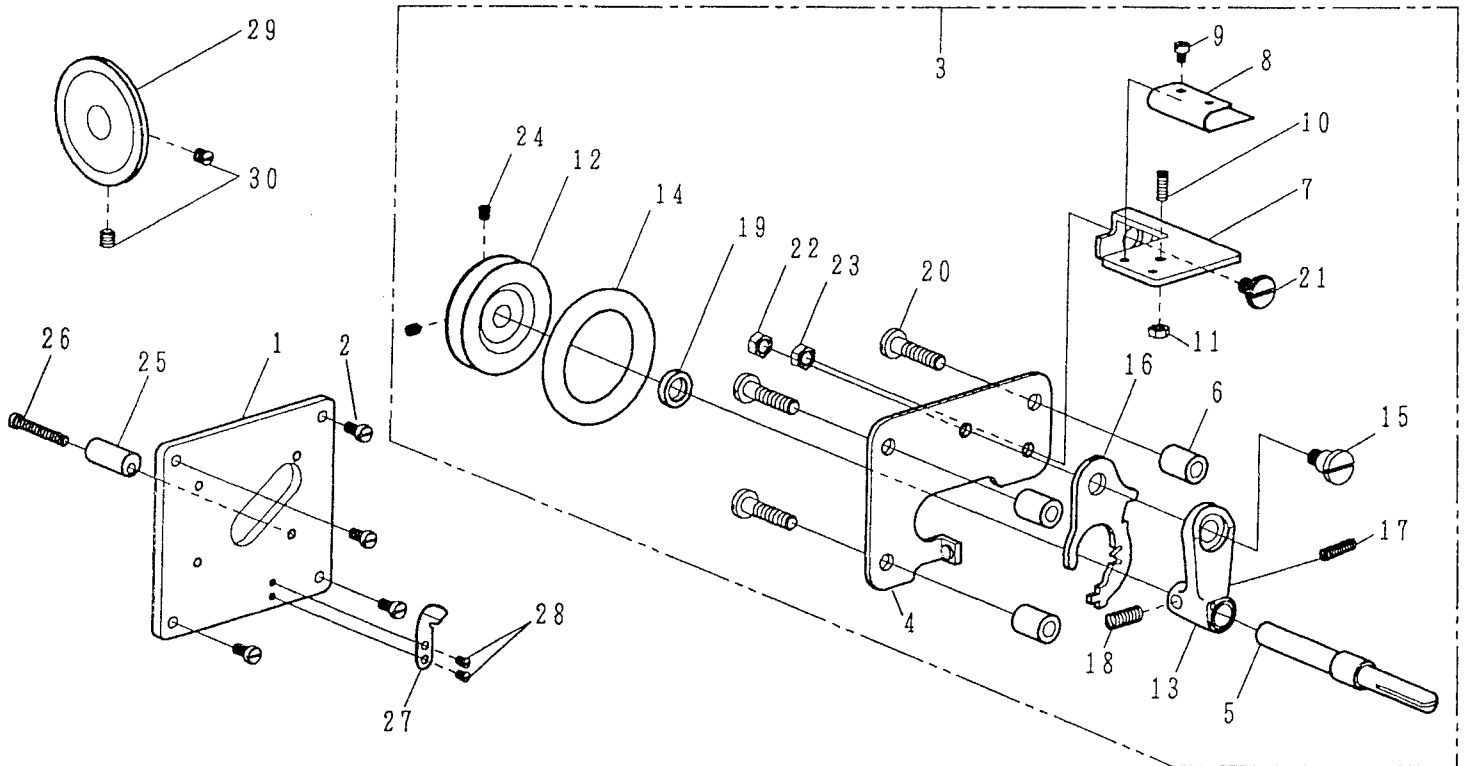

REF.No	Part No.	Name of Part	Q'TY
1	4710320100	Thread Winder Plate	1
2	ZSB11011	Screw 11/64-40 L=9	4
3	4710320805	Thread Winder Asm.	1
4	4710320800	Thread Winder Base	(1)
5	4710320900	Thread Winder Shaft	(1)
6	4710321000	Spacer	(3)
7	4710321100	Bobbin Presser	(1)
8	4710321200	Bobbin Presser Spring	(1)
9	ZSB06008	Screw 3/32-56 L=3.3	(2)
10	ZSA08007	Adjusting Screw	(1)
11	ZSL08001	Nut 1/8-44	(1)
12	4710321300	Bobbin Winder Wheel	(1)
13	4710321400	Bobbin Winder Frame	(1)
14	4710322000	Wheel Ring	(1)
15	ZSG11059	Hinge Screw	(1)
16	4710321500	Bobbin Winder Tension Bracket	(1)
17	4710321600	Spring	(1)
18	4710321800	Bobbin Winder Spring	(1)
19	4710321900	Thread Winding Shaft Collar	(1)
20	ZSB11083	Screw 11/64-40 L=18	(3)
21	ZSG11057	Hinge Screw D=7.24 L=1.9	(1)
22	ZSL11007	Nut 11/64-40	(1)
23	ZSL11007	Nut 11/64-40	(1)
24	ZSA11003	Screw 11/64-40 L=5	(2)
25	4710320300	Stopper	1
26	ZSB11071	Screw 11/64-40 L=30	1
27	4710320400	Thread Cut & Clamp Plate	1
28	ZSB08008	Screw 1/8-44 L=4	2
29	4710320500	Friction Wheel	1
30	ZSA15028	Screw 15/64-28 L=7	2

H. THREAD WINDER & THREAD GUIDE COMPONENTS (2/2)

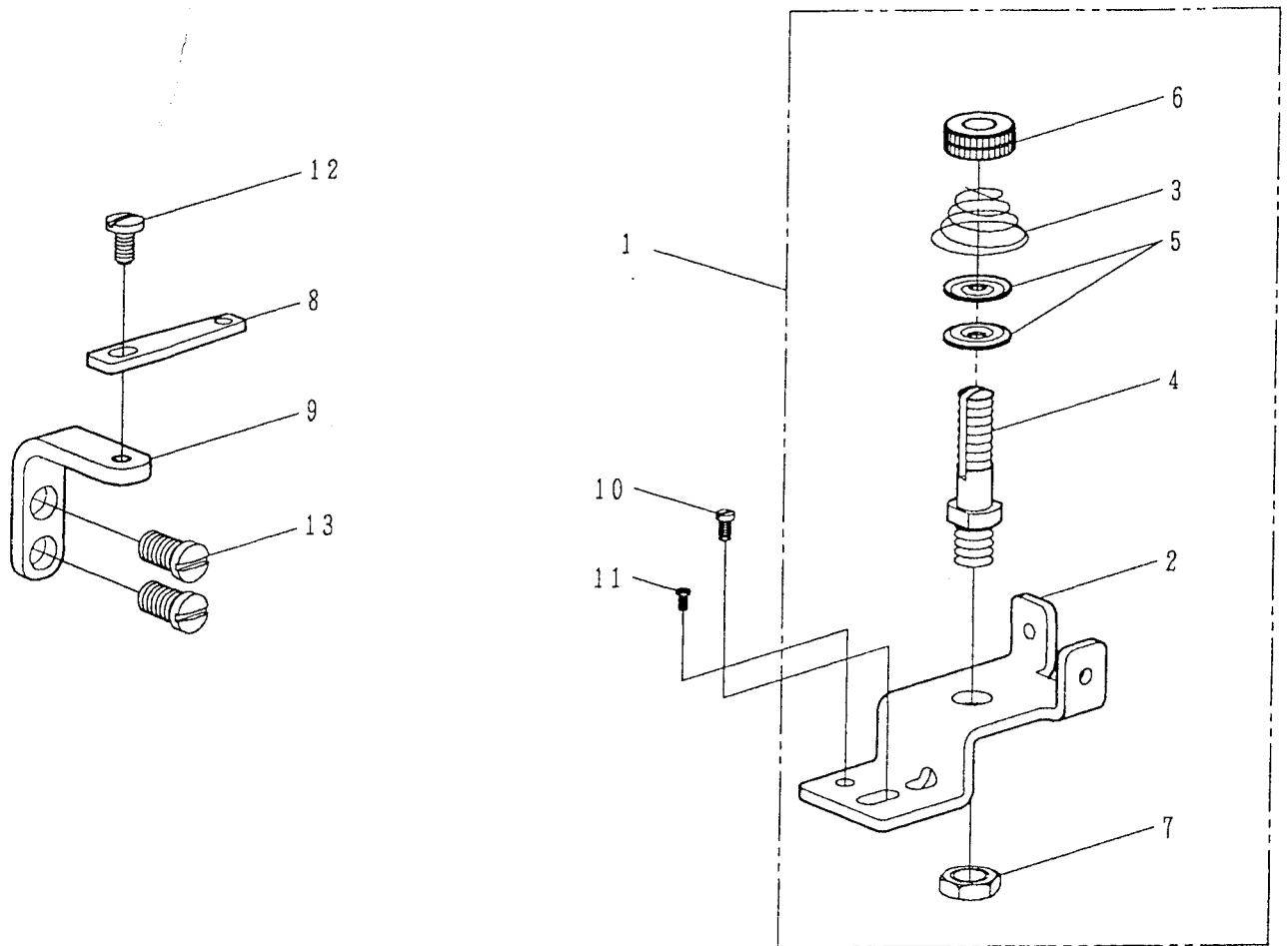

REF.No	Part No.	Name of Part	Q'TY
1	4710313005	Thread Winder Guide Base Asm.	1
2	4710313000	Thread Winder Guide Base	(1)
3	4710313100	Tension Sping	(1)
4	4710310100	Thread Tension Post	(1)
5	A1025-0A	Tension Disk	(2)
6	ZSN16004	Thread Tension Stud' Nut	(1)
7	ZSL18003	Nut 9/32-28	(1)
8	4710322200	Thread Guide	1
9	4710322300	Guide Bracket	1
10	ZSB11015	Screw 11/64-40 L=8.5	1
11	ZSB08001	Screw 1/8-44 L=6	1
12	ZSB09047	Screw 9/64-40 L=7	1
13	ZSB15004	Screw 15/64-28 L=10.5	2

I. KNEE LIFTER COMPONENTS

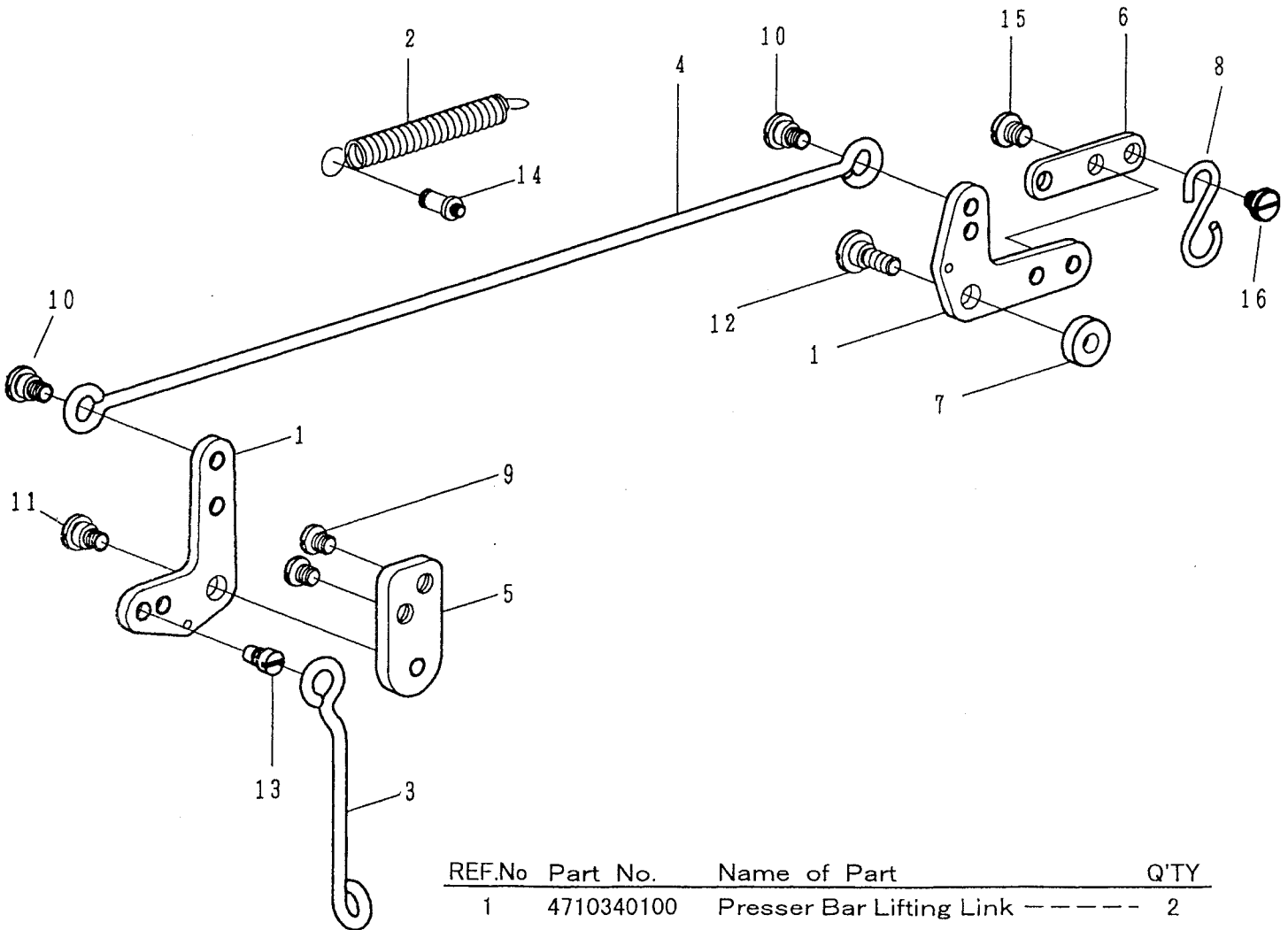

REF.No	Part No.	Name of Part	Q'TY
1	4710340100	Presser Bar Lifting Link	2
2	4710340200	Presser Bar Lifting Spring	1
3	4710340300	Presser Bar Lifting Bar	1
4	4710340400	Side Connecting Bar	1
5	4710340500	Link Base	1
6	4710340600	Link Plate	1
7	4710340700	Link Collar	1
8	4710340800	S-Plug	1
9	ZSB15001	Screw 15/64-28 L=6.5	2
10	ZSG15045	Hinge Screw D=7.94 L=4.3	2
11	ZSG15045	Hinge Screw D=7.94 L=4.3	1
12	ZSG15046	Hinge Screw D=7.94 L=4.3	1
13	4710341200	Hinge Screw	1
14	ZSK11037	Spring Suspension	1
15	ZSB15001	Screw 15/64-28 L=6.5	2
16	ZSG16025	Hinge Screw D=8.0 L=3.4	1

J. BELT COVER COMPONENTS

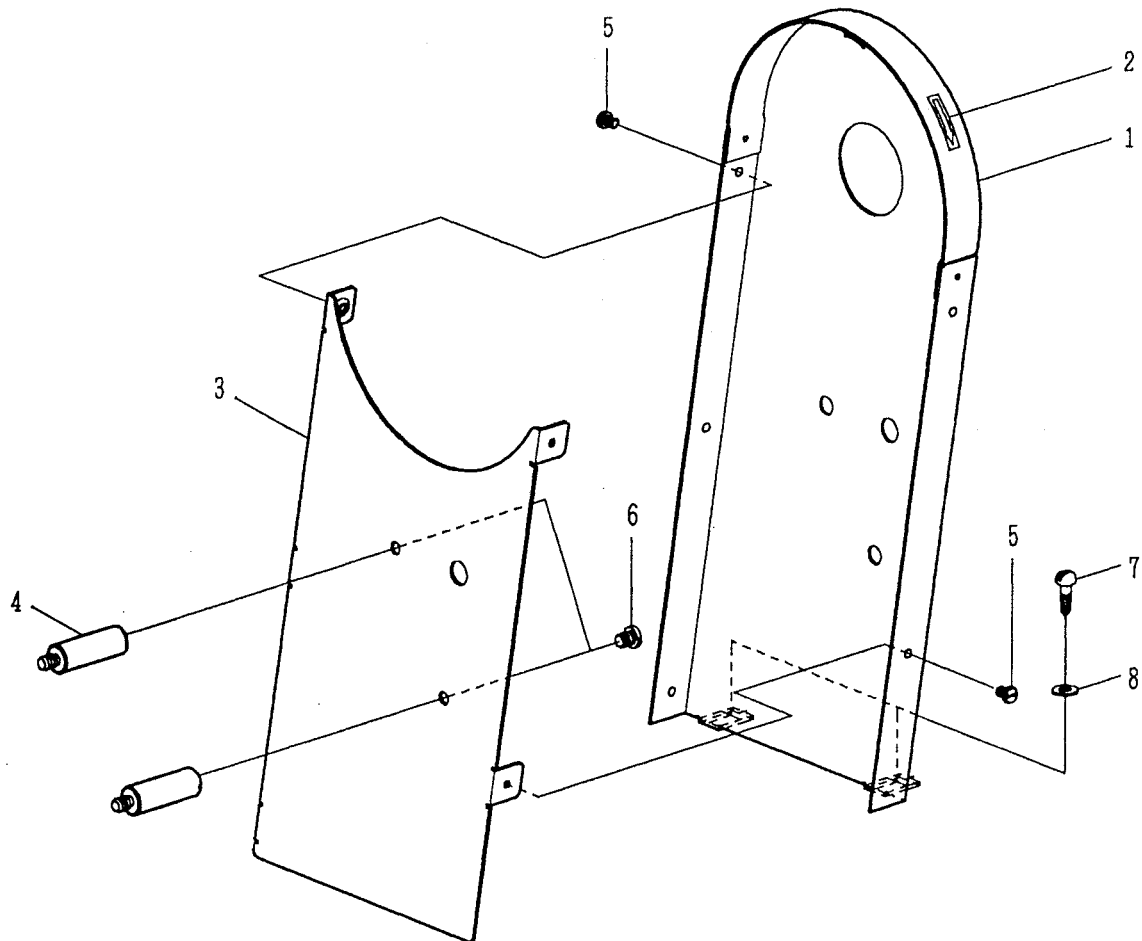

REF.No	Part No.	Name of Part	Q'TY
1	4710335100	Belt Cover A-----	1
2	4710335400	Direction Label-----	1
3	4710335200	Belt Cover B-----	1
4	4710335300	Belt Cover Stud -----	2
5	ZSB11008	Screw 11/64-40 L=5 -----	5
6	ZSB15001	Screw 15/64-28 L=6.5 -----	2
7	ZMT05003	Wood Screw D=8.3 L=18 -----	2
8	WA059005	Washer 5X10.5X1 -----	2

K. THREAD STAND COMPONENTS

REF.No	Part No.	Name of Part	Q'TY
1	A7050-0A	Shread Stand	1
2	ZMT05001	Wood Screw L=18	3

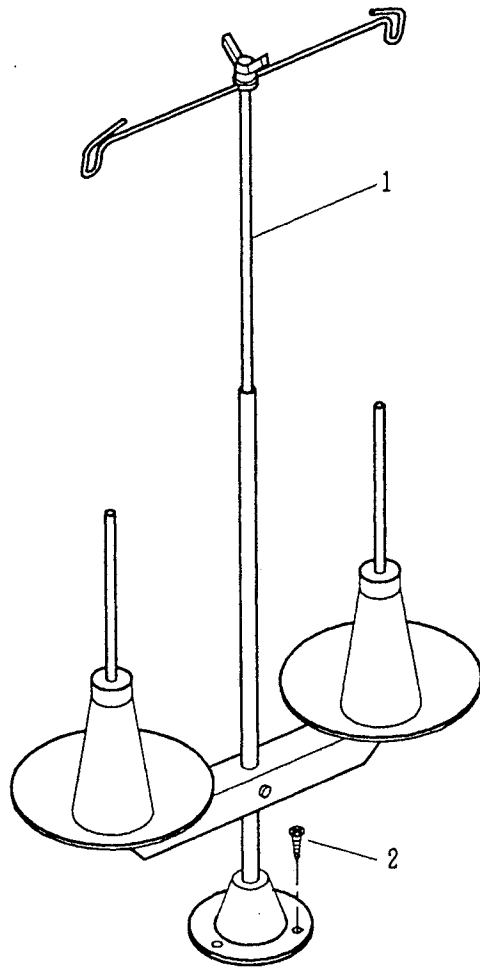

L. TABLE COMPONENTS

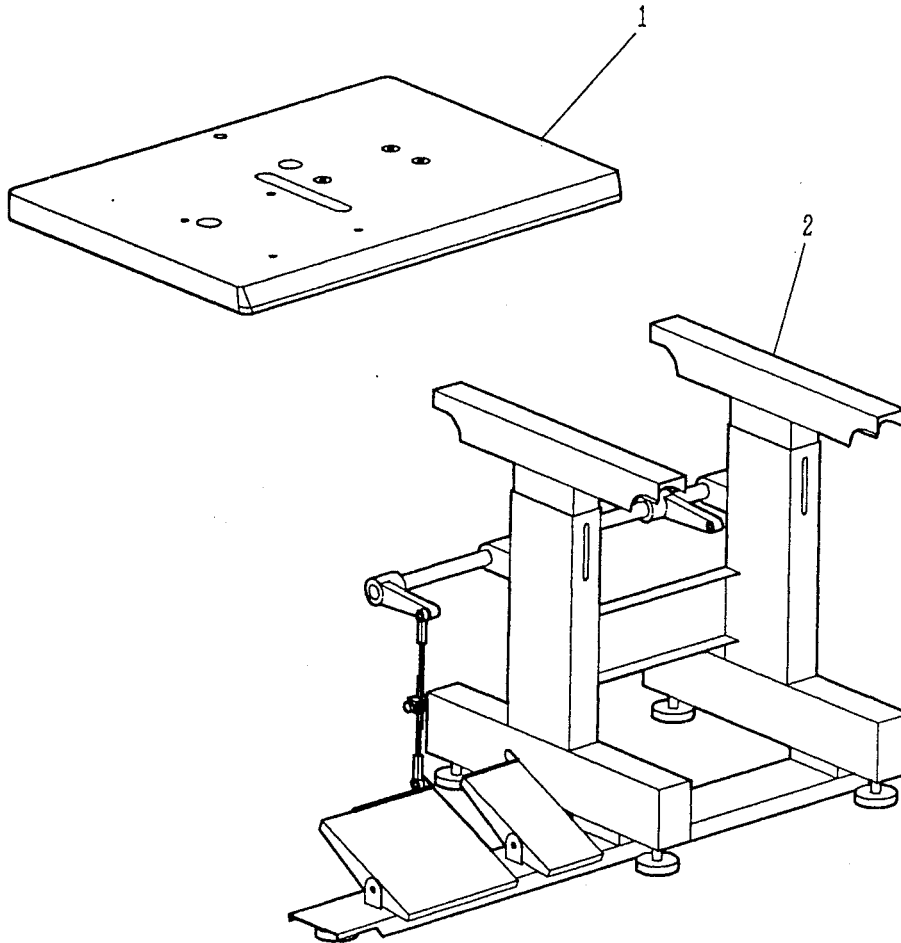

REF.No	Part No.	Name of Part	Q'TY
1	4710820100	Table -----	1
2	0	Stand -----	1

M. ACCESSORIES PARTS COMPONENTS

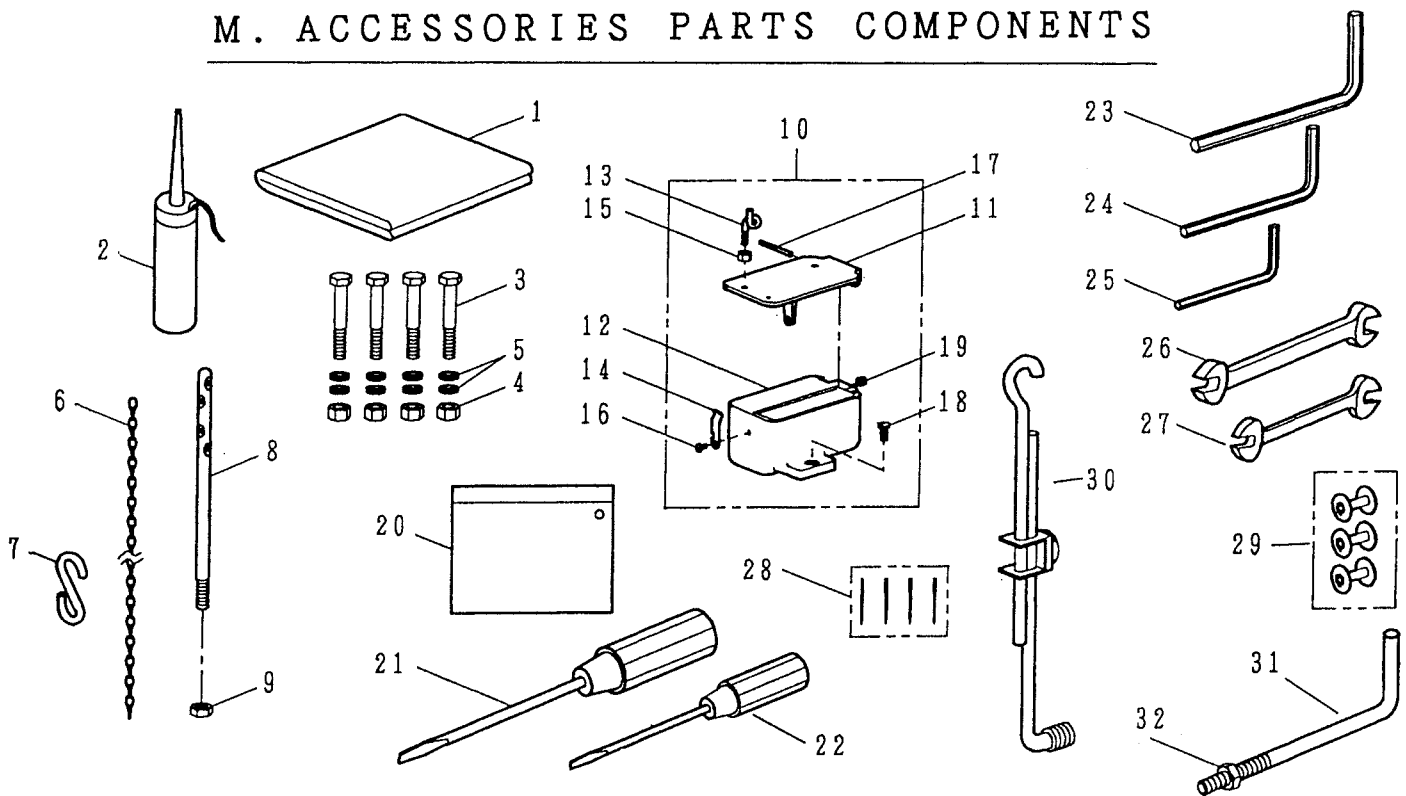

REF.No	NOTE	Part No.	Name of Part	Q'TY
1		A7001-0A	Cover	1
2		A7012-1A	Oiler Asm.	1
3		ZMD10002	Screw M10 L=65	4
4		ZML10004	Nut M10	4
5		WA110003	Washer 11X21X2	8
6		4710341400	Chain	1
7		4710340800	S-Plug	1
8		4710113400	Needle Thread Guide Pin	1
9		ZSL12003	Nut 3/16-32	1
10		4710911005	Oil Pot Asm.	1
11		4710911100	Oil Pot Cover	(1)
12		4710911000	Oil Pot	(1)
13		4710911200	Frame Thread Guide	(1)
14		4710911300	Cover Stopper	(1)
15		ZSL06001	Nut 3/32-56	(1)
16		ZSB09047	Screw 9/64-40 L=7	(1)
17		4710911400	Pin	(1)
18		ZSB15005	Screw 15/64-28 L=12	(1)
19		ZSA09005	Screw 9/64-40 L=3.5	(1)
20		A7000-0A	Accessory Box	1
21		A7010-2A	Screw Driver, Large	1
22		A7010-0A	Screw Driver, Small	1
23		EH7141-5A	Hexagonal Wrench Key(5mm)	1
24		EH7141-6A	Hexagonal Wrench Key(4mm)	1
25		EH7141-4A	Hexagonal Wrench Key(3mm)	1
26		LG7200-0A	Wrench (11X14)	1
27		LG7201-0A	Wrench (9X10)	1
28		IN794#230	Needle (794 Nm=230-4)	1
29		4710183200	Bobbin	3
30	#06	0	Motor Connecting Rod Asm.	(1)
31	#03	0	Supporting Arm	(1)
32	#03	ZSL15004	Nut 15/64-28	(1)

Notes #03..... Optional part
#06..... H & M only

N. NUMERICAL PARTS—LIST (1/3)

<u>Part No.</u>	<u>PAGE/#</u>	<u>Part No.</u>	<u>PAGE/#</u>	<u>Part No.</u>	<u>PAGE/#</u>
4410111005	3-1	4710122500	5-13	4710151600	17-18
4410111200	3-4	4710140100	11-1	4710151700	17-19
4410111300	3-6	4710140400	11-2	4710151800	17-20
4410111400	3-16	4710140500	11-27	4710151900	17-21
4410121000	5-6	4710140500	11-3	4710152000	17-22
4410140100	9-1	4710140700	11-4	4710152500	17-16
4410140200	9-5	4710140900	11-5	4710160100	19-1
4410140900	9-3	4710141200	11-7	4710160200	19-2
4410141900	7-6	4710141300	11-8	4710160300	19-3
4410142000	7-9	4710142000	11-14	4710160404	19-4
4410142100	7-1	4710142101	11-15	4710160600	19-5
4410142300	7-4	4710142201	11-16	4710160700	19-6
4410142400	7-5	4710142301	11-17	4710160800	19-8
4410142900	9-26	4710142401	11-18	4710160900	21-1
4410143100	7-7	4710142500	11-19	4710161000	21-2
4410143300	9-24	4710142600	11-20	4710161100	21-3
4410143600	9-23	4710142700	11-21	4710161200	21-4
4410143700	9-6	4710142800	11-22	4710161300	21-5
4410143800	17-12	4710142900	11-23	4710161400	19-10
4410143805	17-11	4710143000	11-24	4710161600	21-6
4410145600	7-2	4710143100	13-1	4710161700	19-11
4410150100	9-22	4710143200	13-2	4710161800	21-7
4410150400	17-4	4710143300	13-3	4710161900	21-8
4410150500	17-6	4710143400	13-4	4710162000	21-9
4410151000	9-25	4710143500	13-5	4710162100	19-12
4410151100	9-30	4710143600	13-6	4710162200	21-10
4410152500	17-13	4710143700	13-7	4710162300	21-11
4410160800	19-7	4710143800	13-8	4710180100	23-4
4410161400	19-9	4710143900	11-25	4710180300	23-5
4410181600	23-7	4710144100	13-12	4710180500	23-6
4410270100	9-2	4710144200	13-16	4710181300	23-16
4410270200	9-9	4710144401	15-1	4710181400	23-8
4410270400	9-11	4710144500	15-2	4710181800	25-1
4410272200	9-8	4710144600	15-3	4710181900	25-2
4410272300	9-7	4710144700	15-4	4710182000	25-3
4410273000	9-10	4710144800	15-5	4710182100	25-11
4710111005	3-2	4710144900	15-6	4710182200	25-4
4710111100	3-3	4710145000	15-7	4710182300	25-5
4710111200	3-5	4710145100	15-8	4710182400	25-6
4710111300	3-7	4710150100	17-1	4710182500	23-1
4710111400	3-17	4710150200	17-2	4710182600	23-2
4710111600	3-8	4710150300	17-3	4710182700	23-3
4710113400	41-8	4710150400	17-5	4710182800	25-7
4710120300	5-3	4710150500	17-7	4710182900	25-8
4710120400	5-4	4710150600	17-8	4710183000	25-9
4710121000	5-7	4710150700	17-9	4710183100	25-10
4710121100	5-8	4710150800	17-10	4710183200	23-9
4710121300	5-9	4710151000	17-15	4710183200	41-29
4710122000	5-10	4710151005	17-14	4710183600	23-10
4710122100	5-11	4710151500	17-17	4710183700	23-11
4710122304	5-12	4710151600	17-18	4710183800	23-12

N. NUMERICAL PARTS—LIST (2/3)

Part No.	PAGE/#	Part No.	PAGE/#	Part No.	PAGE/#
4710183900	23-13	4710335100	35-1	RE000040	5-31
4710184000	23-14	4710335200	35-3	RE000080	11-40
4710184200	23-20	4710335300	35-4	RE000080	13-18
4710184210	23-17	4710335400	35-2	RE000080	13-19
4710184220	23-18	4710340100	33-1	RE000080	13-22
4710184230	23-19	4710340200	33-2	RE000080	15-17
4710184240	23-21	4710340300	33-3	RE000080	19-19
4710184250	23-22	4710340400	33-4	RE000080	19-22
4710184260	23-23	4710340500	33-5	RE000080	7-19
4710190100	5-25	4710340600	33-6	RE000080	7-20
4710190200	5-26	4710340700	33-7	RE000080	9-29
4710190220	5-27	4710340800	33-8	S1013-0A	3-10
4710190230	5-28	4710340800	41-7	WA059005	35-8
4710190300	5-29	4710341200	33-13	WA100009	17-31
4710191301	5-5	4710341400	41-6	WA110003	41-5
4710310100	27-1	4710820100	39-1	WC049001	3-14
4710310100	31-4	4710911000	41-12	WH208005	15-10
4710310400	27-4	4710911005	41-10	XA200100	9-21
4710310500	27-5	4710911100	41-11	XA200160	5-15
4710310600	27-6	4710911200	41-13	XA300085	25-16
4710310700	27-7	4710911300	41-14	XB123001	27-13
4710310800	27-8	4710911400	41-17	YB040016	23-27
4710310900	27-9	4710113300	27-25	YB040045	5-18
4710311000	27-10	4710120101	5-1	YD025014	11-37
4710311100	27-11	4710120201	5-2	YD030020	17-32
4710311200	27-12	4710122601	5-14	YD050018	3-9
4710311400	27-14	4710142201	7-3	ZMD10002	41-3
4710311605	27-15	A1025-0A	27-2	ZMH06005	9-12
4710312000	27-16	A1025-0A	31-5	ZMH06005	9-14
4710313000	31-2	A7000-0A	41-20	ZMH06005	9-17
4710313005	31-1	A7001-0A	41-1	ZMH06010	9-13
4710313100	31-3	A7010-0A	41-22	ZMJ06002	11-33
4710320100	29-1	A7010-2A	41-21	ZMJ06002	15-13
4710320300	29-25	A7012-1A	41-2	ZMJ06002	9-18
4710320400	29-27	A7050-0A	37-1	ZMJ06004	19-21
4710320500	29-29	E1288-0A	13-17	ZMJ08003	23-28
4710320800	29-4	EH7141-4A	41-25	ZMJ08003	25-13
4710320805	29-3	EH7141-5A	41-23	ZML10004	41-4
4710320900	29-5	EH7141-6A	41-24	ZMT05001	37-2
4710321000	29-6	IN794#230	11-6	ZMT05003	35-7
4710321100	29-7	IN794#230	41-28	ZSA08007	29-10
4710321200	29-8	IN794#230	9-4	ZSA09005	41-19
4710321300	29-12	LG1274-0A	11-34	ZSA11003	29-24
4710321400	29-13	LG1275-0A	25-17	ZSA15010	23-25
4710321500	29-16	LG4014-0A	19-28	ZSA15010	23-26
4710321600	29-17	LG4043-0A	11-28	ZSA15010	25-12
4710321800	29-18	LG4043-0A	7-10	ZSA15010	5-16
4710321900	29-19	LG4044-0A	19-27	ZSA15013	11-9
4710322000	29-14	LG4044-0A	23-30		
4710322200	31-8	LG7200-0A	41-26		
4710322300	31-9	LG7201-0A	41-27		

N. NUMERICAL PARTS—LIST (3/3)

Part No.	PAGE/#	Part No.	PAGE/#	Part No.	PAGE/#
ZSA15028	11-30	ZSB12015	21-15	ZSH16005	17-23
ZSA15028	11-35	ZSB12016	17-30	ZSH16005	7-14
ZSA15028	11-36	ZSB12036	21-16	ZSH16005	9-16
ZSA15028	15-16	ZSB12036	25-20	ZSJ15001	25-21
ZSA15028	19-25	ZSB12045	3-11	ZSJ16001	17-29
ZSA15028	25-15	ZSB15001	33-15	ZSK11037	33-14
ZSA15028	29-30	ZSB15001	33-9	ZSK18018	21-12
ZSA15028	5-21	ZSB15001	35-6	ZSK18019	13-10
ZSA15028	7-12	ZSB15004	31-13	ZSK18019	13-11
ZSA15028	7-13	ZSB15004	9-20	ZSK18019	13-20
ZSA15037	19-20	ZSB15005	13-21	ZSK18019	15-11
ZSA15037	19-26	ZSB15005	13-23	ZSK18019	7-8
ZSA16010	11-29	ZSB15005	41-18	ZSK18019	9-28
ZSA16010	7-11	ZSB15014	3-12	ZSK18020	21-13
ZSA16025	15-12	ZSB15015	7-15	ZSK20006	13-9
ZSA16025	5-24	ZSB15019	21-17	ZSK20007	19-13
ZSA16029	19-23	ZSB15032	11-11	ZSK20009	11-26
ZSA16029	23-31	ZSC09005	27-23	ZSK20009	19-14
ZSA16039	11-10	ZSC11002	25-14	ZSK20009	19-15
ZSA16039	17-24	ZSC11007	5-22	ZSK20009	7-18
ZSB06008	29-9	ZSC18001	5-20	ZSL06001	41-15
ZSB08001	31-11	ZSD11010	25-18	ZSL08001	29-11
ZSB08008	29-28	ZSD20003	5-23	ZSL09001	17-28
ZSB09014	27-21	ZSD20009	7-17	ZSL11002	25-19
ZSB09047	27-22	ZSD20011	15-14	ZSL11004	11-39
ZSB09047	27-24	ZSD20011	7-16	ZSL11007	29-22
ZSB09047	3-13	ZSF18001	13-14	ZSL11007	29-23
ZSB09047	31-12	ZSG06004	23-15	ZSL12003	41-9
ZSB09047	41-16	ZSG11057	29-21	ZSL15002	27-19
ZSB09061	17-27	ZSG11058	13-13	ZSL15004	41-32
ZSB11008	35-5	ZSG11059	29-15	ZSL16004	19-17
ZSB11011	27-20	ZSG12046	27-18	ZSL18001	21-14
ZSB11011	29-2	ZSG12047	23-24	ZSL18001	5-19
ZSB11015	31-10	ZSG15045	33-10	ZSL18001	5-32
ZSB11018	3-15	ZSG15045	33-11	ZSL18003	13-15
ZSB11022	11-12	ZSG15046	33-12	ZSL18003	23-29
ZSB11022	9-15	ZSG16024	19-16	ZSL18003	27-17
ZSB11026	13-24	ZSG16025	33-16	ZSL18003	31-7
ZSB11035	19-24	ZSG20012	5-30	ZSL22001	15-15
ZSB11041	19-18	ZSG22002	15-9	ZSN16004	27-3
ZSB11041	9-27	ZSH16001	11-32	ZSN16004	31-6
ZSB11042	9-31	ZSH16001	17-26		
ZSB11057	11-38	ZSH16001	5-17		
ZSB11071	29-26	ZSH16002	11-31		
ZSB11076	11-13	ZSH16005	17-23		
ZSB11076	9-19	ZSH16005	7-14		
ZSB11083	29-20	ZSH16005	9-16		
ZSB12002	17-25				

Parts Manual for Models 756R-3 & 757R-3



Main Office
131 West 25th Street
New York, NY 10001
Tel: 212-741-7788
Fax: 212-741-7787

Miami Branch Office
7855 N.W. 29th St. (#166)
Miami, FL 33122
Tel: 305-471-0200
Fax: 305-471-0243

West Coast Branch Office
1400 South Broadway
Los Angeles, CA 90015
Tel: 213-745-8844
Fax: 213-745-8855

e-mail: consew@worldnet.att.net

web: www.consew.com

From the library of: Superior Sewing Machine & Supply LLC